

DLD ELECTRIC BRUSH SELF-CLEANING FILTER FW SERIES

PRINCIPLE DESCRIPTIONS

The water flows through the screen and the particles are retained on the screen of the filter element. The filtered water flows out through the outlet. When the particles accumulated to a certain number and the pressure differential increases to the pre-determined level, the flushing cycle starts. It includes two steps: First, the automatic drain valve opens on the drainage outlet. Then the electric motor drives the cleaning brushes inside the screen and the solids are expelled through the drain valve. Filters continue to supply filtered water when back washing. The whole working system is controlled by controller which has several control modes: pressure differential, time, manual and PLC.



MODEL CLARIFICATION

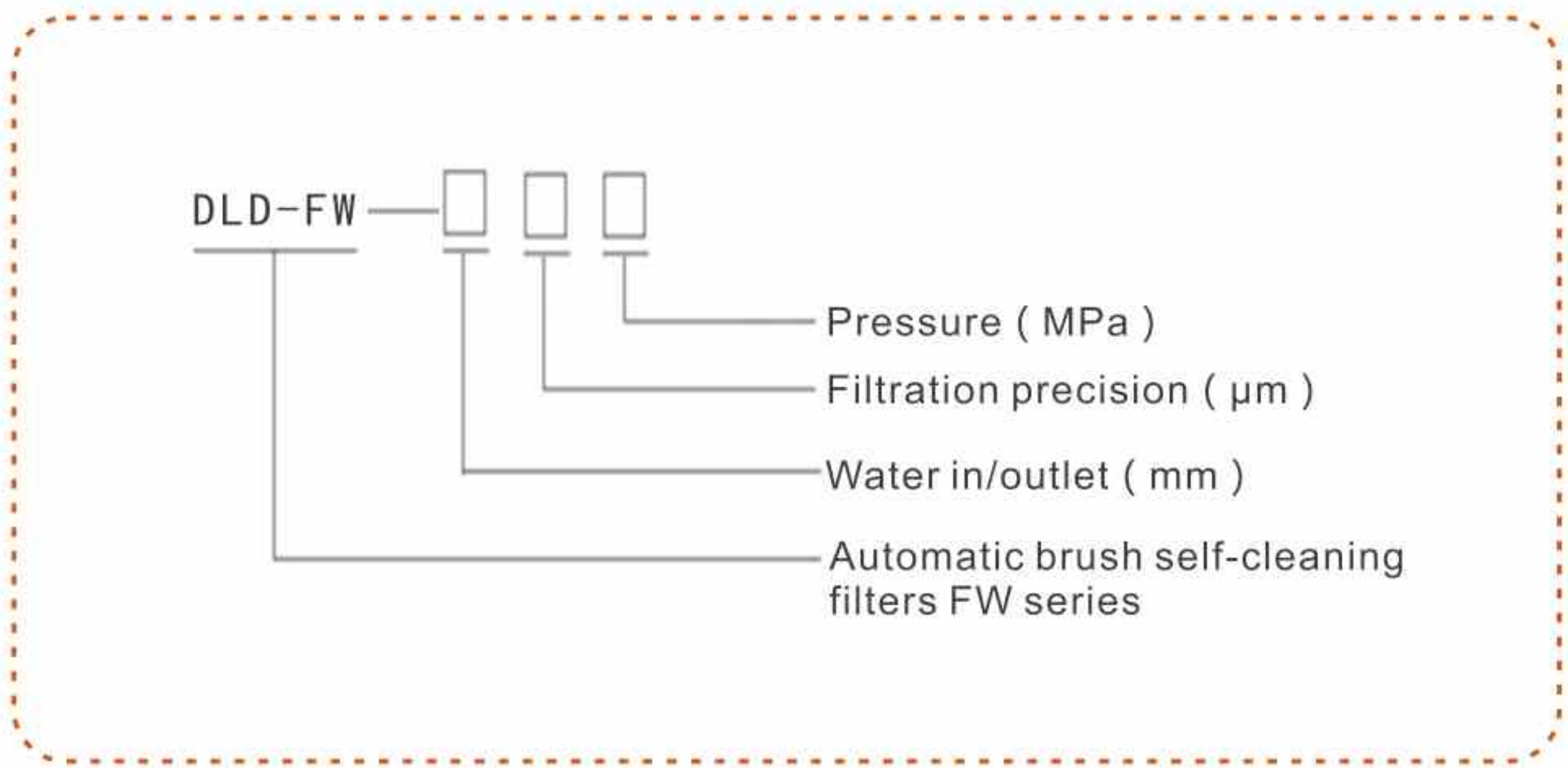

FILTER MATERIAL

- Housing: carbon steel/304 stainless steel/316L
- Mesh: 304 stainless steel/316L
- Brush: 304 stainless steel/316L
- Drain valve: Casting iron, copper, stainless steel, nylon
- Control box: PVC/Aluminium
- Sealing ring: EPDM rubber
- Cleaning brush: stainless steel/nylon

* Various materials can be provided according to the user's requirements. Please consult CDFS company for details.

TECHNICAL PARAMETERS

Single maximum filter flow: 4000m ³ /h
Filtration range: 4000µm~20µm
Max working pressure ≤ 16 bar (customized)
Min working pressure ≥ 1 bar
Working temperature ≤ 85 °C
Power: 380V/50Hz (customized)
Control way: Pressure difference/time/manually/PLC
Cleaning way: brush
Cleaning time: 10~200 seconds (optional)
Drilling (4000~800µm)
Wedge (1000~50µm)
Woven composite (800~20µm)

PRODUCT STRUCTURE CHART

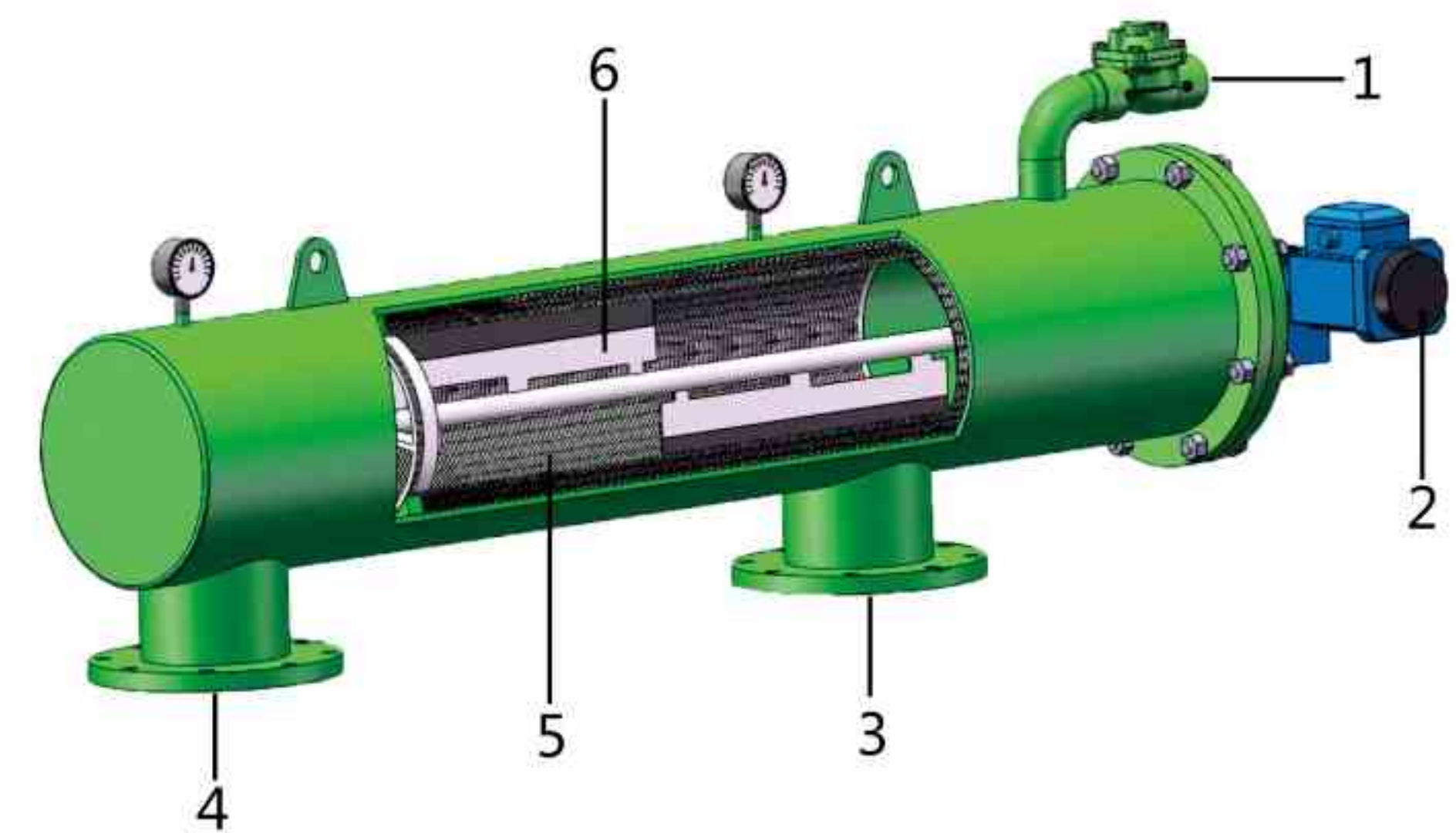

1. Automatic drain valve 2. Electric motor 3. Water outlet
4. Water inlet 5. Screen 6. Cleaning brush

SIZE CHART

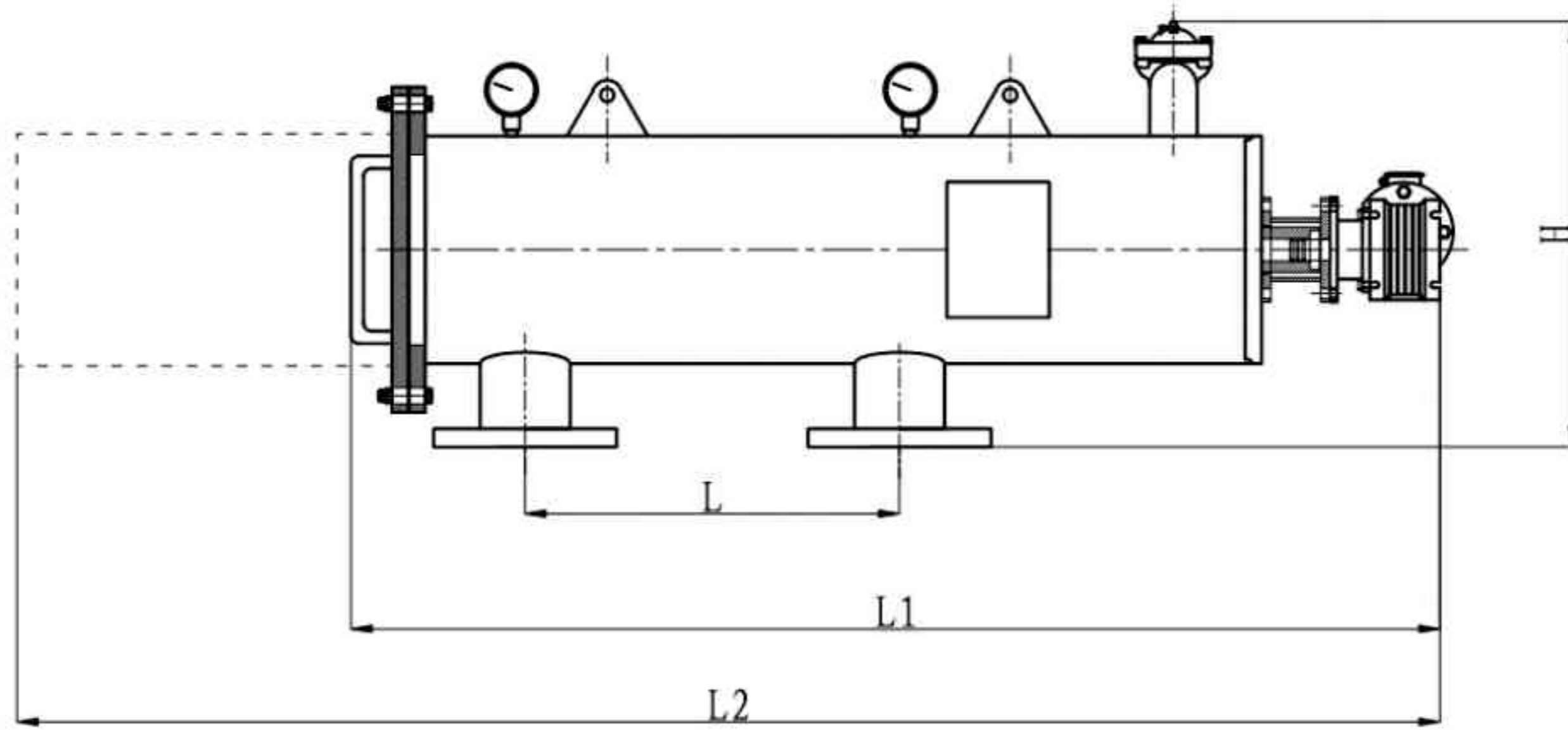

THE TABLE PRESSURE LOSS

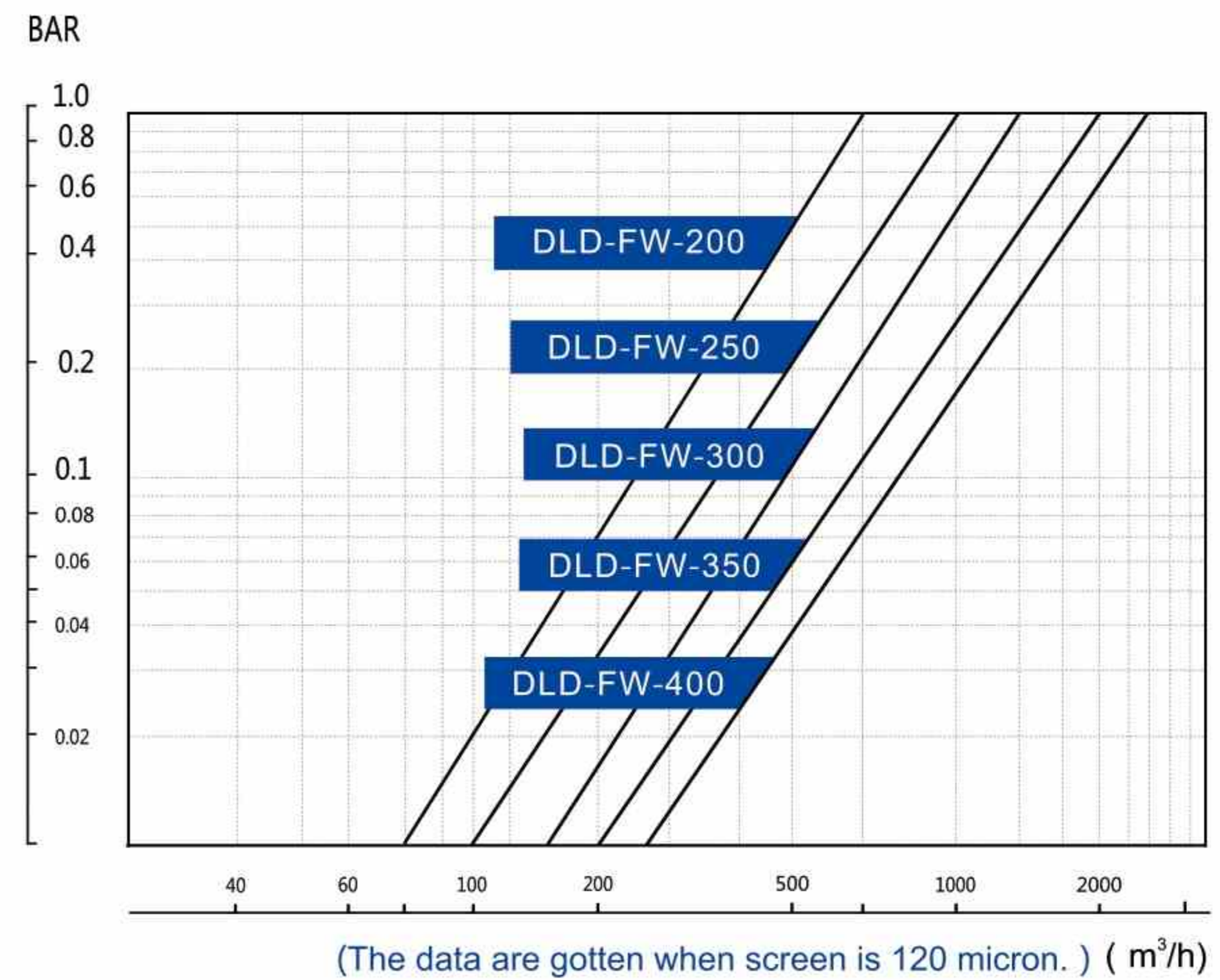

TECHNICAL DATA TABLE

MODEL	WATER IN/OUTLET (mm)	L(mm)	L1(mm)	L2(mm)	H	DRAIN OUTLET (mm)	MOTOR POWER (KW)	FLOW (m ³ /h)	WEIGHT (Kg)
DLD-FW-80	80	450	1338	2038	493	40	0.12	50	180
DLD-FW-100	100	450	1338	2038	493	40	0.18	80	198
DLD-FW-150	150	900	1705	2705	545	50	0.18	150	328
DLD-FW-200	200	900	1765	2765	617	50	0.25	320	375
DLD-FW-250	250	900	1845	2895	720	50	0.25	450	470
DLD-FW-300	300	1100	2442	3792	800	50	0.37	600	519
DLD-FW-350	350	1100	2442	3792	800	50	0.37	850	660
DLD-FW-400	400	1100	2792	4142	900	50	0.37	1200	708

* The actual flow is directly related to water quality and filtration precision. Please consult the company for details.

INSTALLATION FIGURE

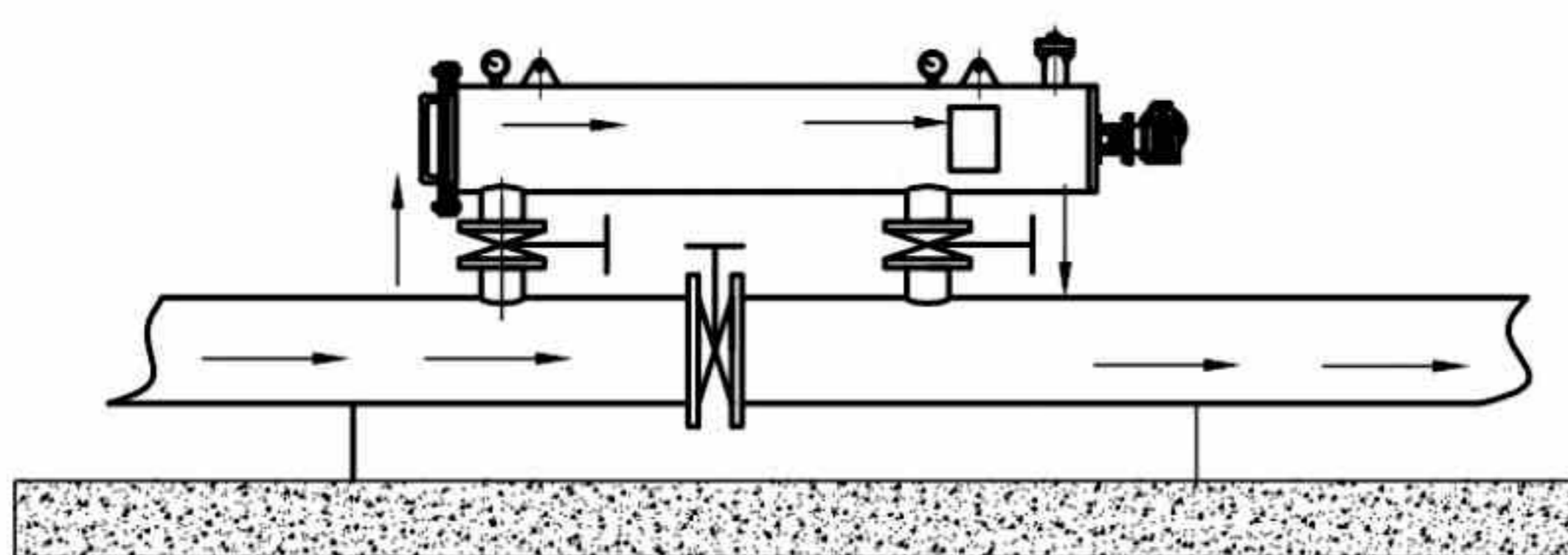

Single filter

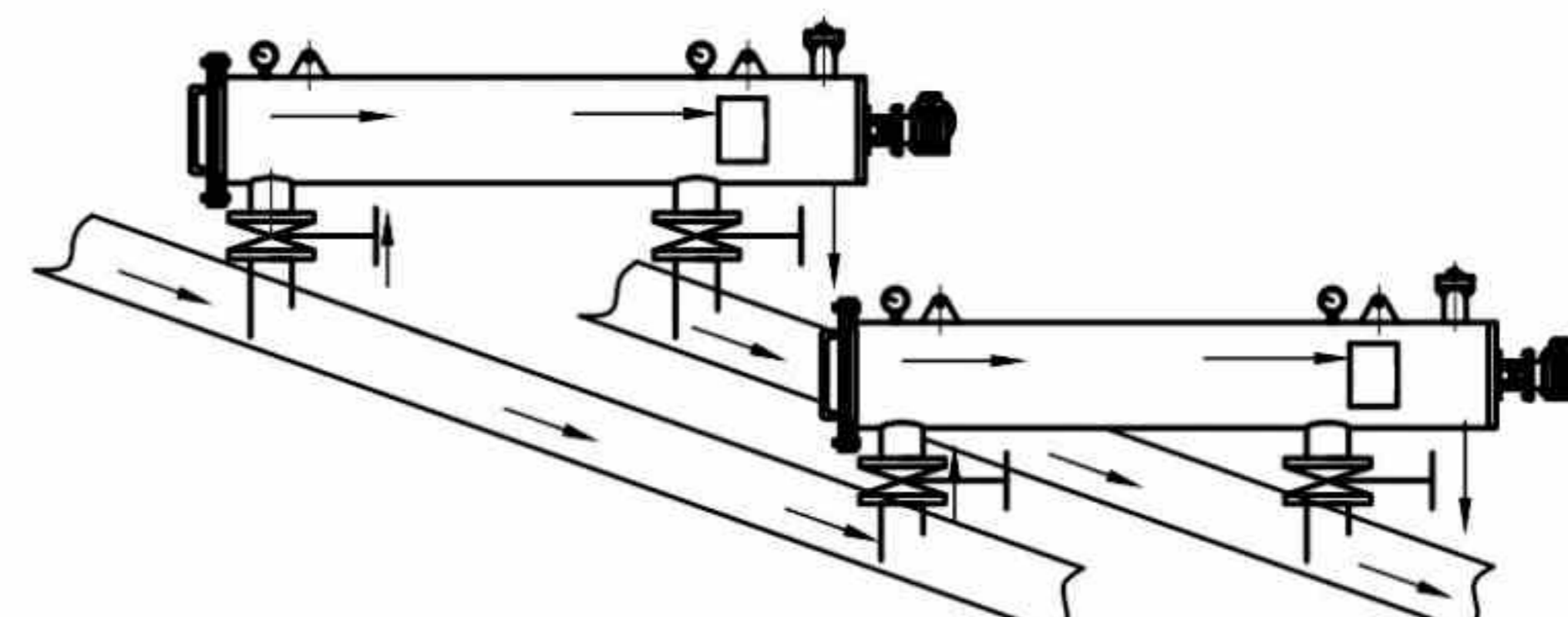

Parallel filters

* Note: the arrow in the diagram is the direction of flow. Vertical or horizontal installation and multiple parallel are available.