

DLD ELECTRIC BRUSH SELF-CLEANING FILTER FZ SERIES

PRINCIPLE DESCRIPTIONS

The water flows through the screen and the particles are retained on the screen of the filter element. The filtered water flows out through the outlet. When the particles accumulated to a certain number and the pressure differential increases to the pre-determined level, the flushing cycle starts. It includes two steps: First, the automatic drain valve opens on the drainage outlet. Then the electronic motor drives the cleaning brushes inside the screen and the solids are expelled through the drain valve. Filters continue to supply filtered water when back washing. The whole working system is controlled by controller which has several control modes: pressure differential, time, manual and PLC.



MODEL CLARIFICATION

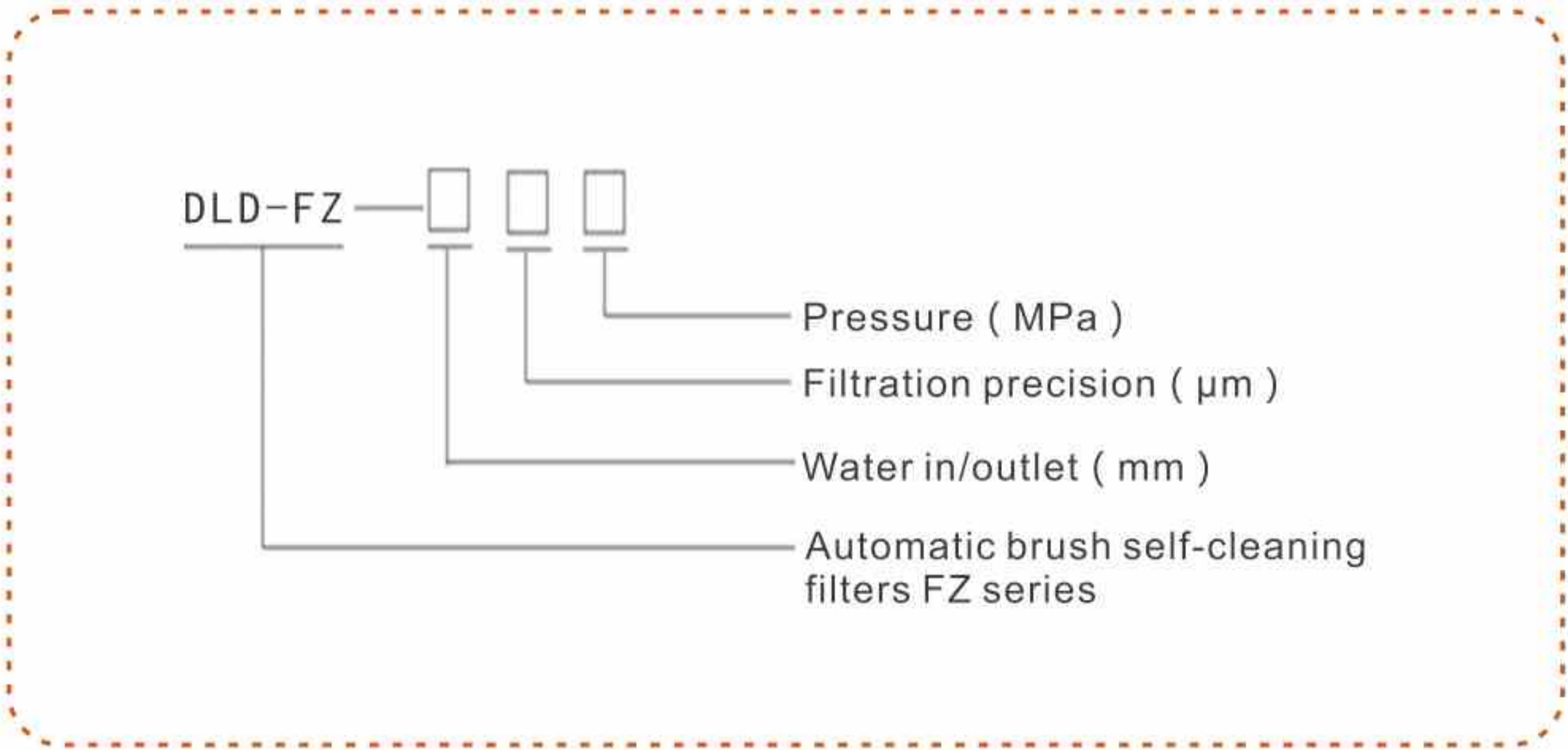

FILTER MATERIAL

- Housing: Carbon steel/304 stainless steel/316L
- Mesh: 304 stainless steel/316L
- Brush: 304 stainless steel/316L
- Drain valve: Casting iron, copper, stainless steel, nylon
- Control box: PVC/Aluminium
- Sealing ring: EPDM rubber
- Cleaning brush: stainless steel/nylon

* Various materials can be provided according to the user's requirements. Please consult CDFS company for details.

TECHNICAL PARAMETERS

Single maximum filter flow: 2000m ³ /h
Filtration range: 4000µm~20µm
Max working pressure ≤ 16 bar (customized)
Min working pressure ≥ 1 bar
Working temperature ≤ 65°C
Power: 380V/50Hz (customized)
Control way: pressure difference/time/manually/PLC
Cleaning way: brush
Cleaning time: 10~200 seconds (optional)
Drilling (4000~800µm)
Wedge (1000~50µm)
Woven composite (800~20µm)

PRODUCT STRUCTURE CHART

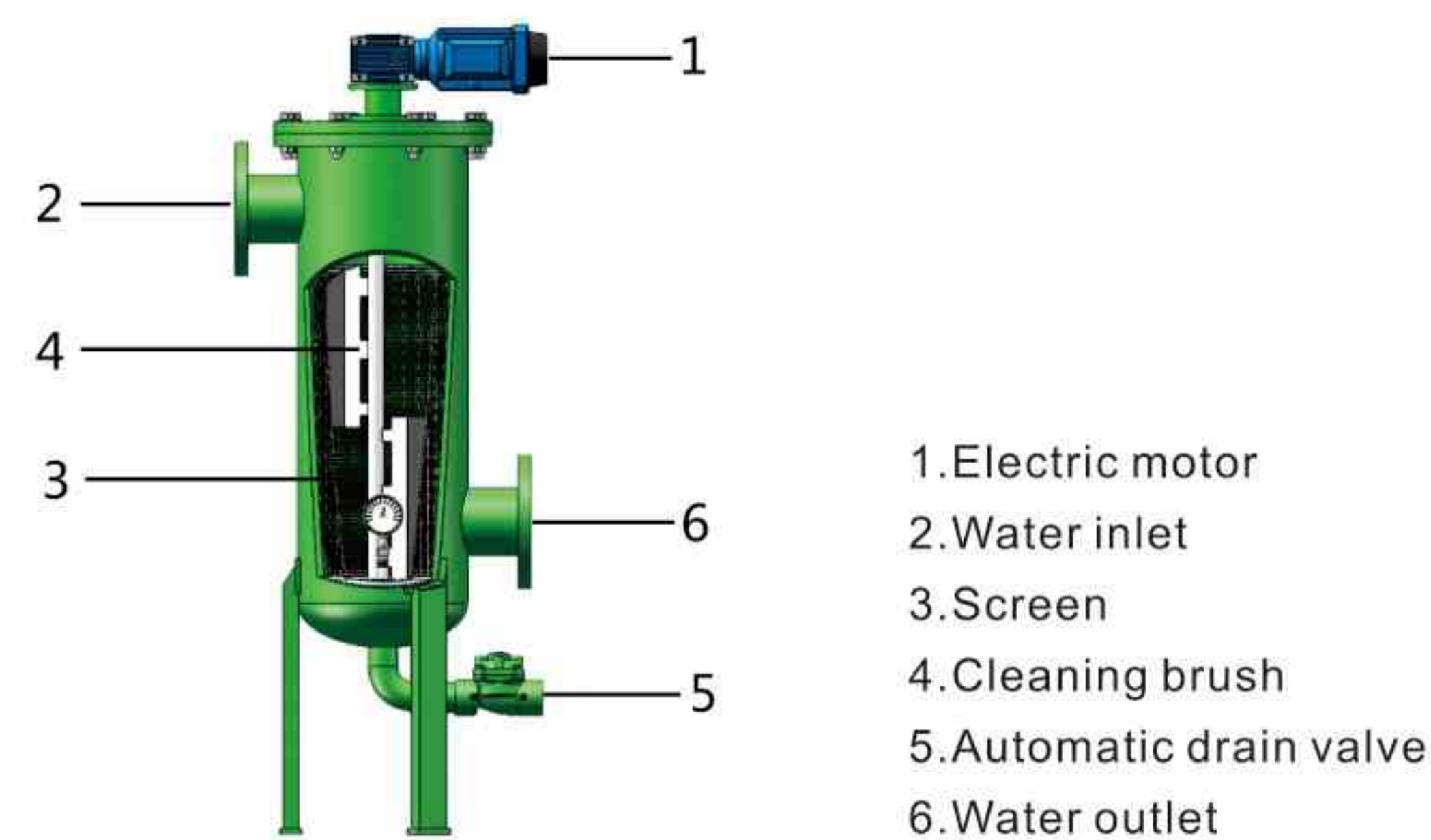

SIZE CHART

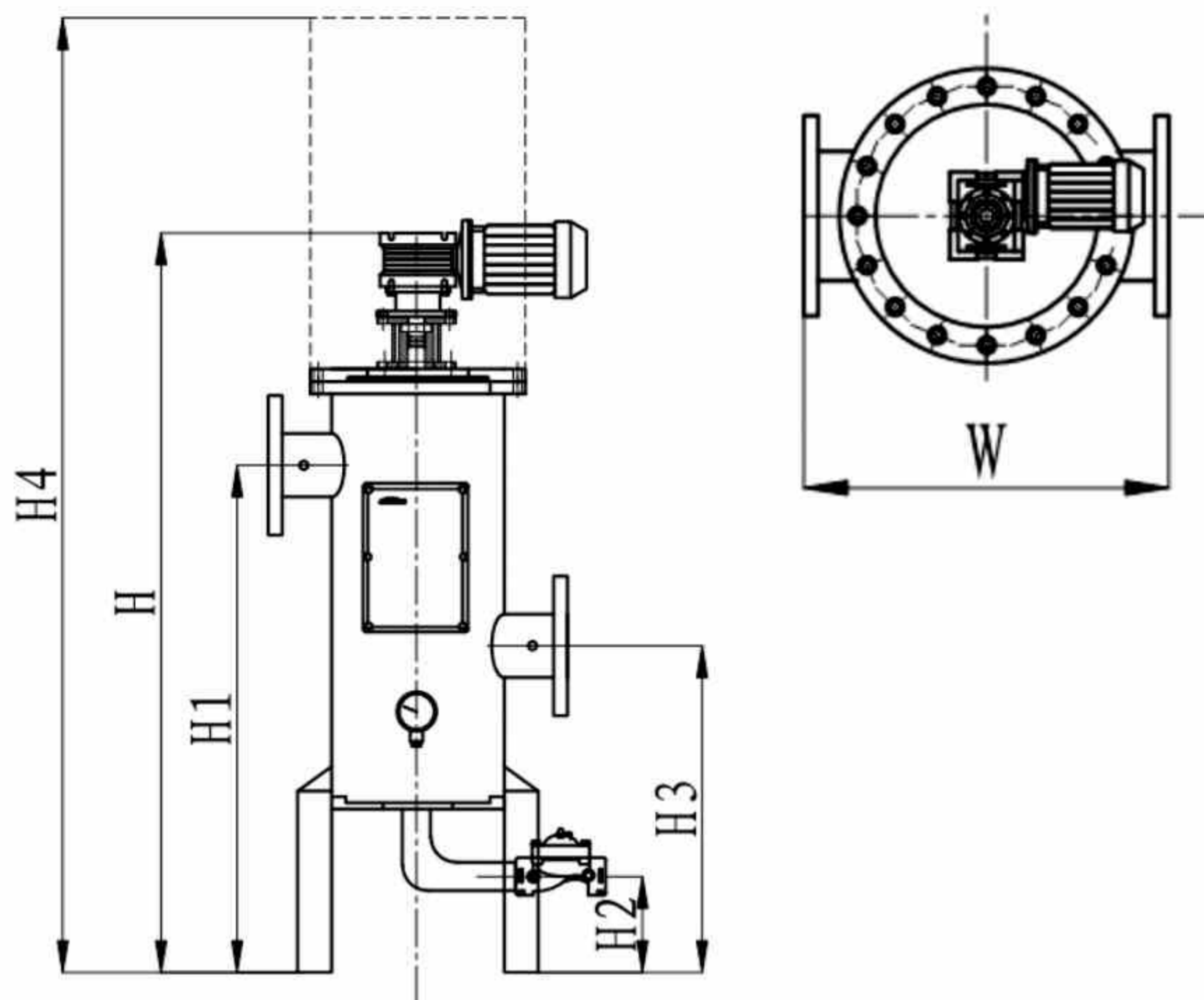

THE TABLE PRESSURE LOSS

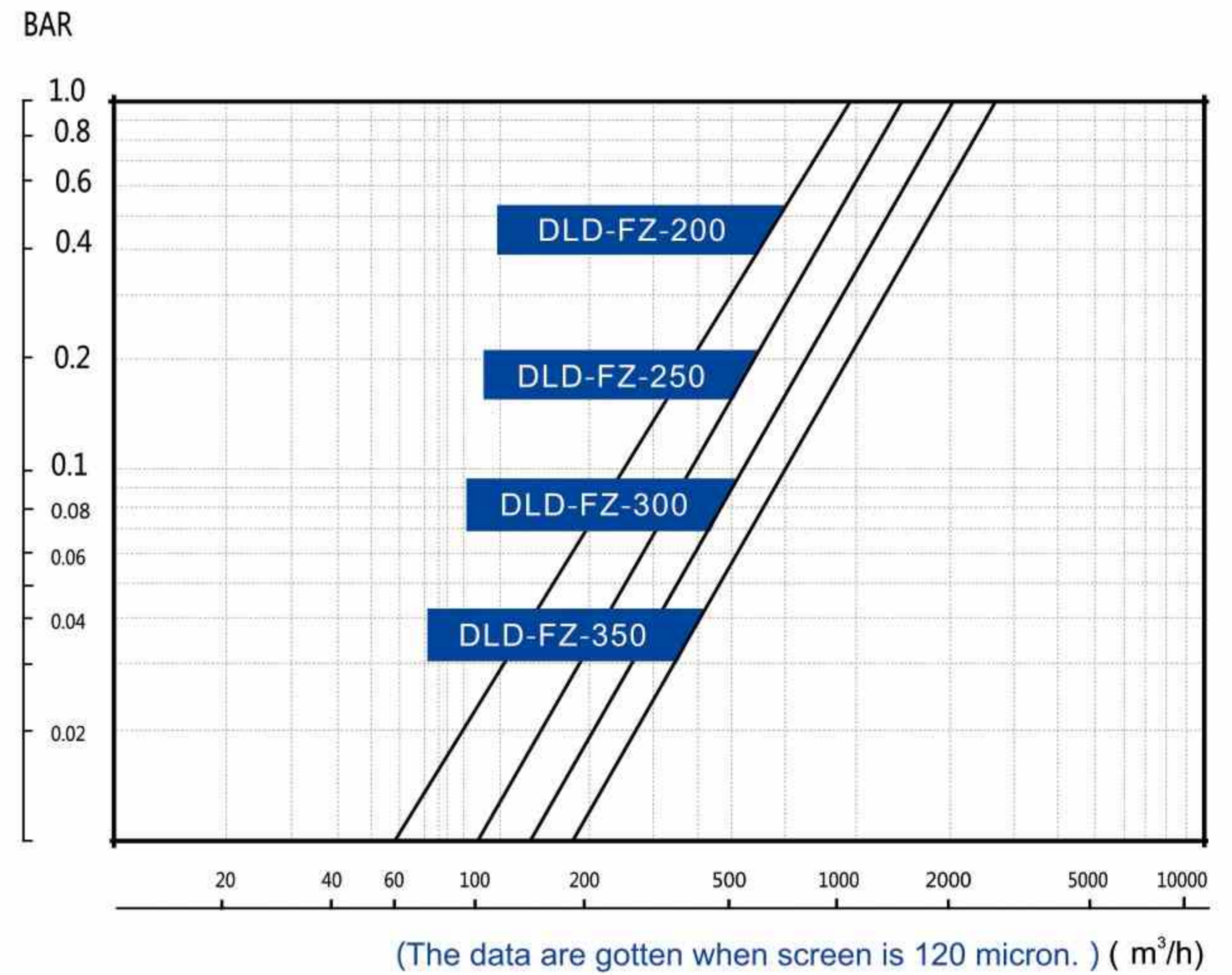

TECHNICAL DATA TABLE

MODEL	WATER IN/OUTLET (mm)	H(mm)	H1(mm)	H2(mm)	H3(mm)	H4(mm)	W(mm)	DRAIN OUTLET (mm)	MOTOR POWER (KW)	FLOW (m ³ /h)	WEIGHT (Kg)
DLD-FZ-50	50	970	670	200	425	1170	453	25	0.12	19	50
DLD-FZ-65	65	970	670	200	425	1170	453	25	0.12	30	70
DLD-FZ-80	80	1010	690	200	425	1210	473	40	0.12	50	87
DLD-FZ-100	100	1280	950	200	550	1580	473	40	0.18	80	106
DLD-FZ-150	150	1470	1110	200	630	1870	473	50	0.18	150	197
DLD-FZ-200	200	1860	1310	200	720	2360	617	50	0.25	320	248
DLD-FZ-250	250	1985	1385	200	745	2490	720	50	0.25	490	360
DLD-FZ-300	300	2350	1660	150	845	3150	770	50	0.37	710	486
DLD-FZ-350	350	2350	1660	150	845	3150	770	50	0.37	970	653
DLD-FZ-400	400	2505	1725	150	845	3310	930	50	0.37	1260	765
DLD-FZ-450	450	2555	1750	150	845	3360	1020	50	0.37	1600	814
DLD-FZ-500	500	2600	1775	150	845	3500	1020	65	0.55	1970	920

* The actual flow is directly related to water quality and filtration precision. Please consult the company for details.

INSTALLATION FIGURE

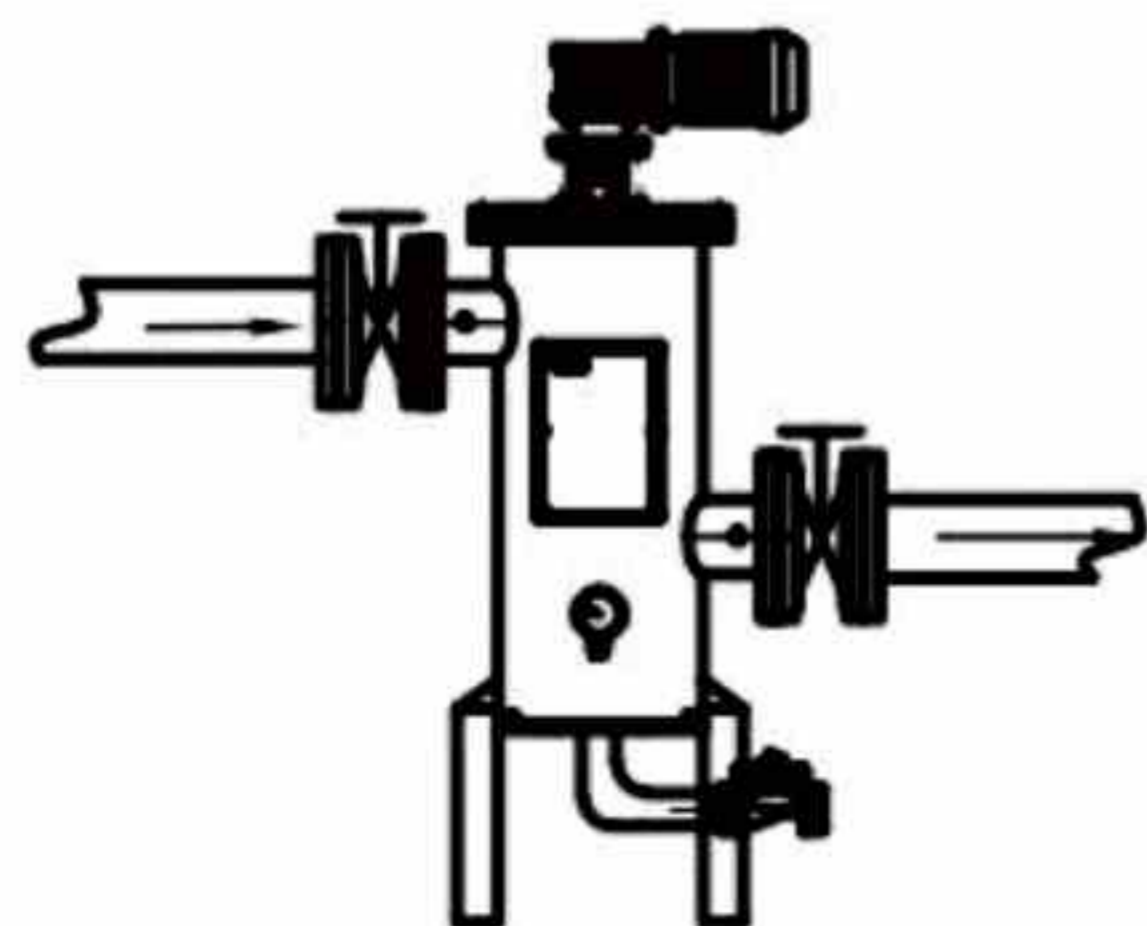

Single filter

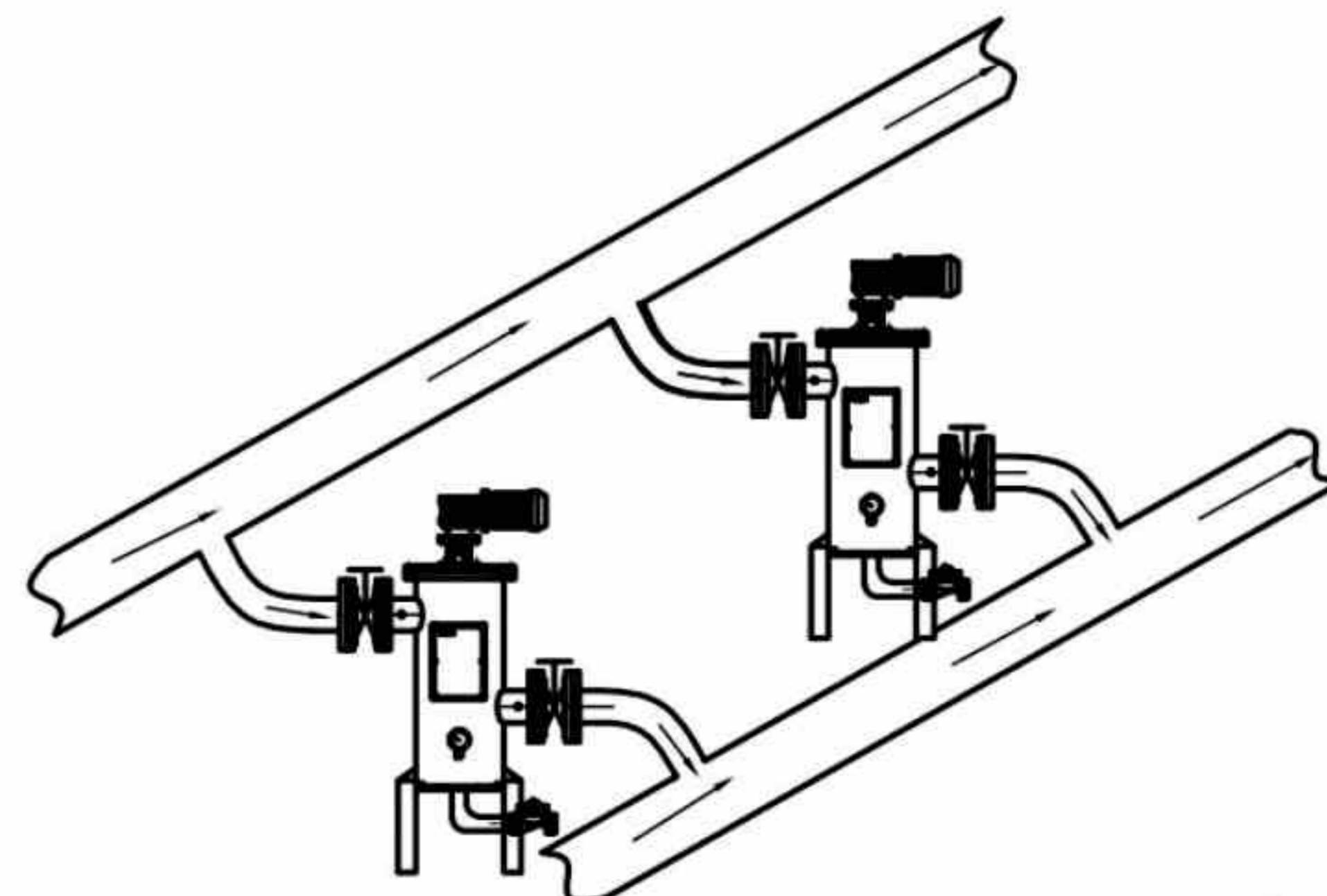

Parallel filters

* Note: the arrow in the diagram is the direction of flow.