

# HYDRAULIC SELF-CLEANING FILTERS DLHF-400 SERIES

## PRINCIPLE DESCRIPTIONS

The water flows through the screen and the particles are retained on the inside of the screen of the filter element. The filtered water then flows out through the outlet.

Self-cleaning mode can be started by pressing, timing or manual three ways, following the principle of pressure difference.

When the internal and external pressure difference( $\Delta P$ )reaches the set value, the self-cleaning mode starts. Drain pipe hydraulic valve open, sucking the scanner to produce negative pressure suction nozzle inside, absorbing impurities, at the same time sucking scanner in under hydraulic motor along the inside surface mesh do reciprocating screw, movement, no cleaning blind area, impurities by the discharge outlet.

The cleaning time of self-cleaning filter is set by the controller in advance, the drain valve is closed after cleaning, and little water loss in cleaning process.



## MODEL CLARIFICATION

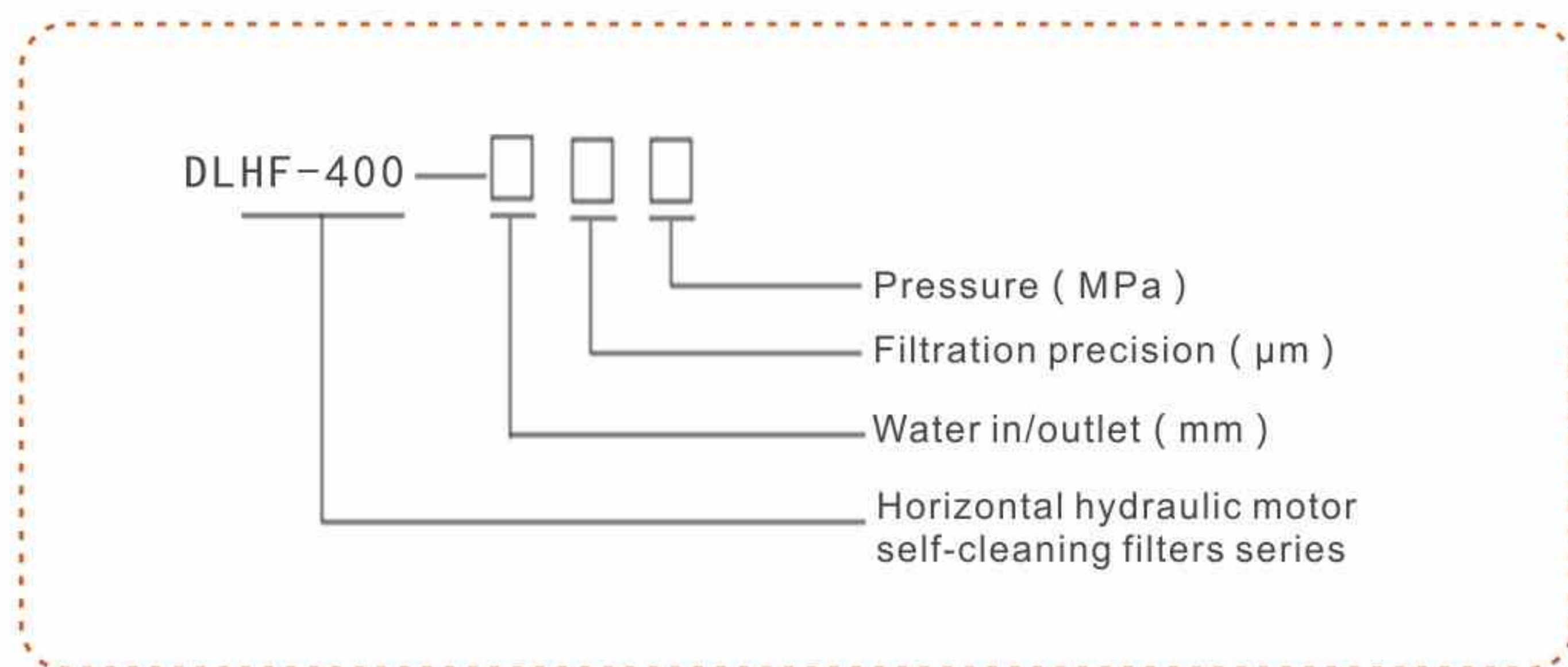

## FILTER MATERIAL

Shell: carbon steel/304 stainless steel/316L

Mesh:304 stainless steel/316L

Sucking scanner: 304 stainless steel/316L

Drain valve: Casting iron, copper, stainless steel, nylon

Sealing ring: EPDM rubber

Control box:PVC/Aluminium

\* Various materials can be provided according to the user's requirements. Please consult CDFS company for details.

## TECHNICAL PARAMETERS

Single filter flow:50-1500m <sup>3</sup> /h
Filtration range:4000µm~25µm
Max working pressure:16 bar
Min working pressure:1 bar
Working temperature≤65°C
Pressure loss:0.1 bar
Control way: pressure difference/time/manually
Cleaning time:10-200seconds(optional)
Power:220V/50Hz
DC:9V
Self-cleaning filter completely depends on the water pressure inside the system and without external power
Screen material:SS361L sintered mesh

## PRODUCT STRUCTURE CHART

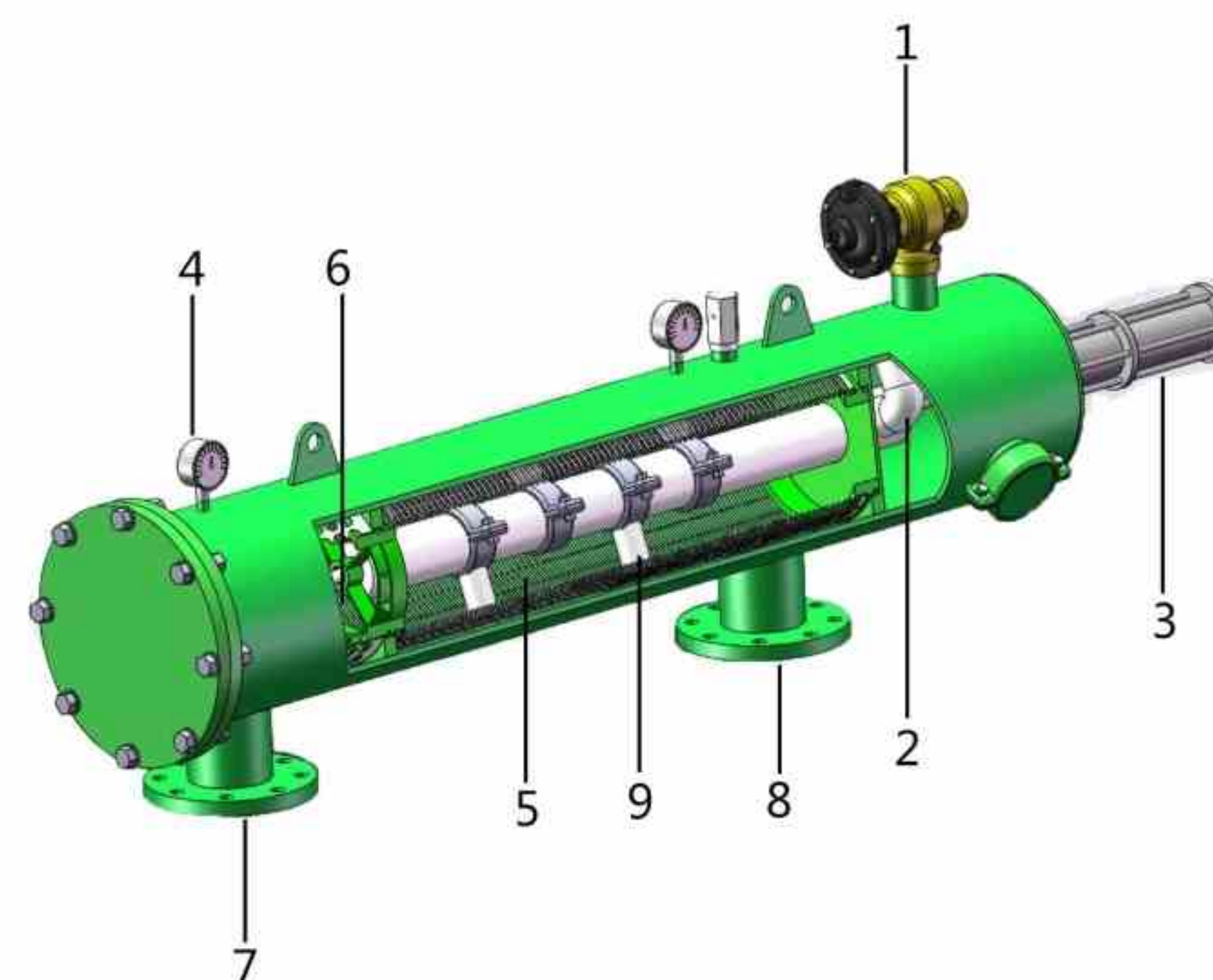

- 1.Drain valve 2.Hydraulic moto 3.Hydraulic piston
- 4.Pressure gauge 5.Fine scree 6.Coarse screen
- 7.Water inlet 8.Water outlet 9.Suction nozzle

## SIZE CHART

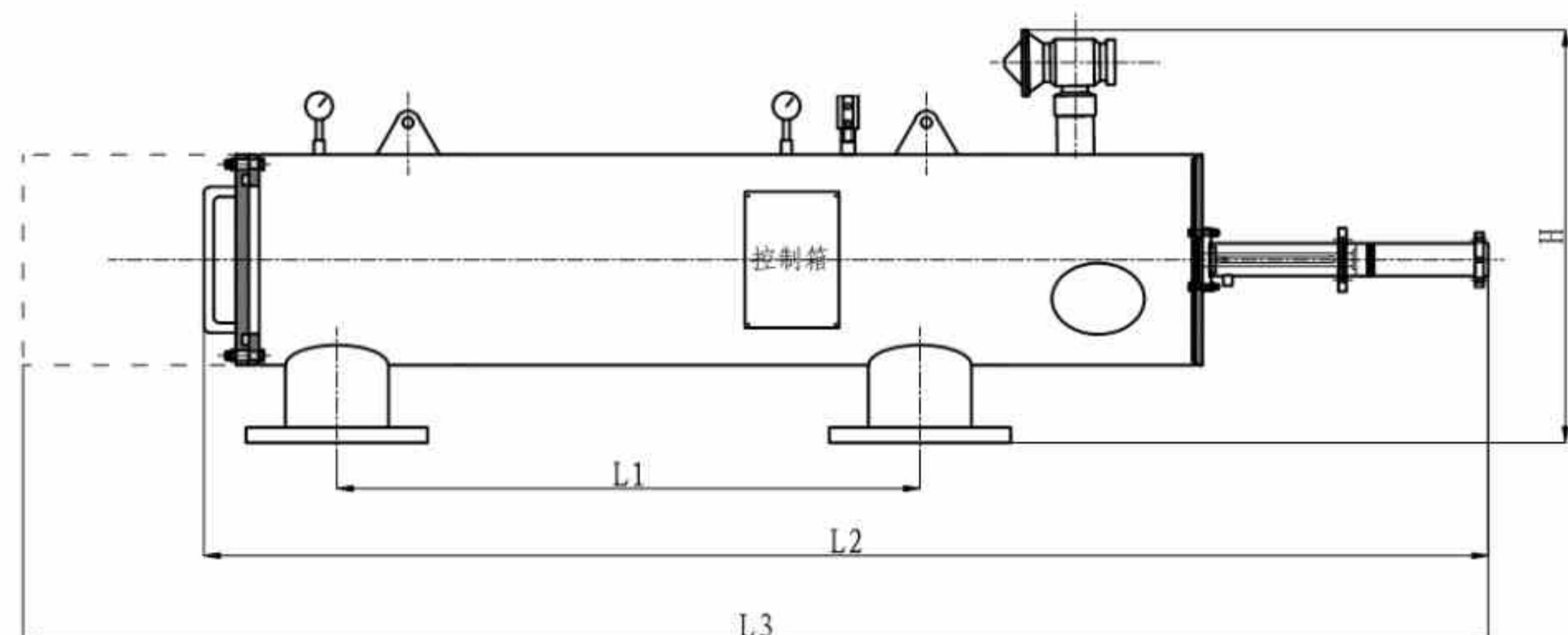

## THE TABLE PRESSURE LOSS

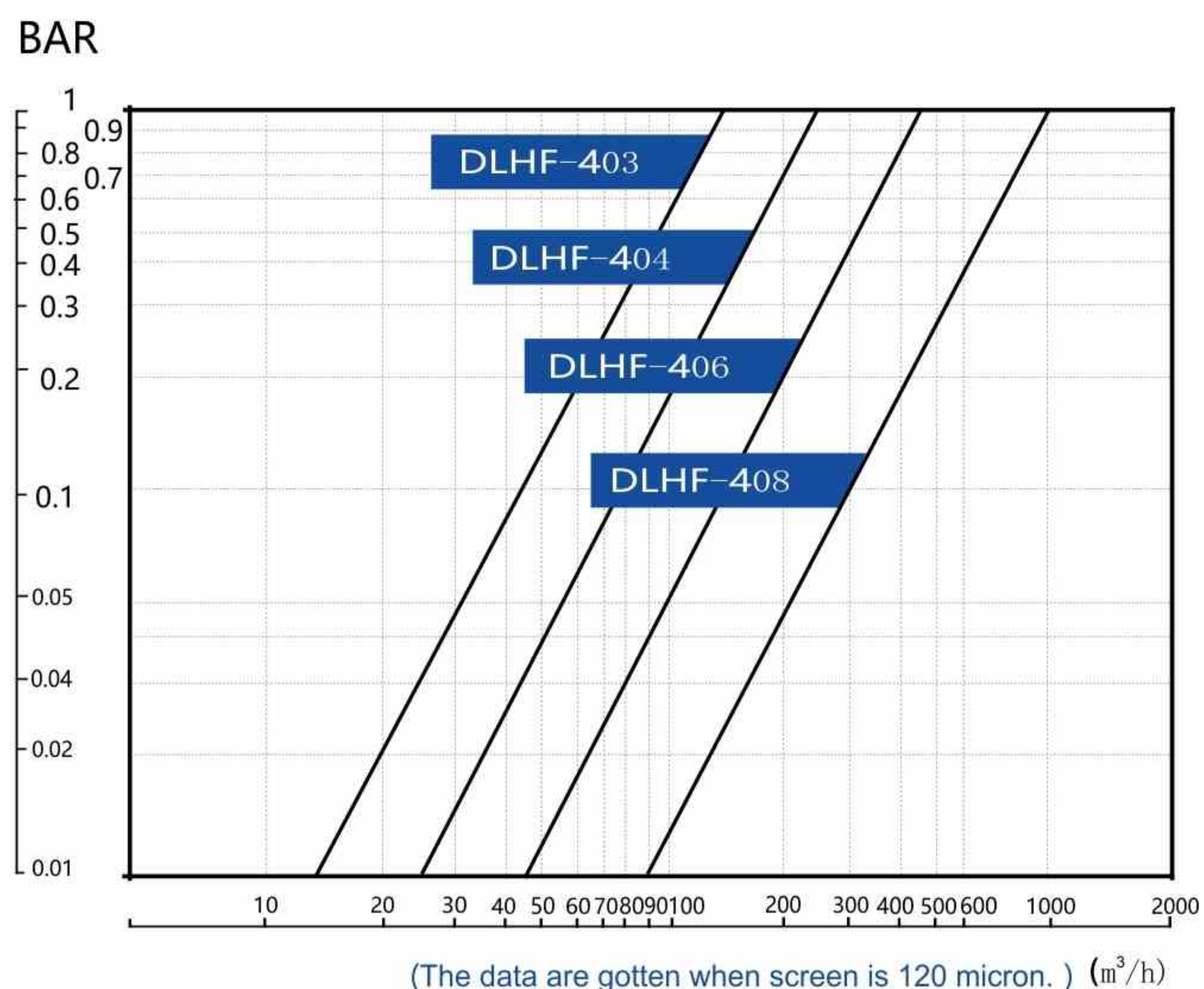

## TECHNICAL DATA TABLE

MODEL	INLET OUTLET (mm)	SCREEN AREA (cm <sup>2</sup> )	D1 (mm)	L(mm)	L1(mm)	L2(mm)	L3(mm)	H(mm)	FLOW (m <sup>3</sup> /h)	WEIGHT (kg)
DLHF403	80	3220	273	450	1141	1575	2075	555	50	140
DLHF404	100	5780	273	900	1505	1935	2735	555	100	170
DLHF406	150	5780	325	900	1505	1935	2735	625	150	183
DLHF406MAX	150	8410	273	900	1841	2275	3471	555	160	205
DLHF408	200	5780	325	900	1685	2115	2915	625	250	195
DLHF408MAX	200	8410	325	900	2085	2515	3715	625	300	235
DLHF410	250	8090	426	900	1885	2315	3515	726	350	250
DLHF410MAX	250	8410	377	900	2085	2515	3715	677	400	270
DLHF410PLUS	250	11710	426	1100	2725	3155	4755	736	450	430
DLHF412	300	11710	426	1100	2725	3155	4755	736	600	435
DLHF414	350	12990	480	1270	2725	3155	4755	810	1000	455
DLHF416	400	12990	480	1270	2725	3155	4755	810	1200	480
DLHF416MAX	400	17020	630	1270	2725	3155	4755	1010	1500	680

\* The actual flow is directly related to water quality and filtration precision. Please consult the company for details.

## INSTALLATION FIGURE

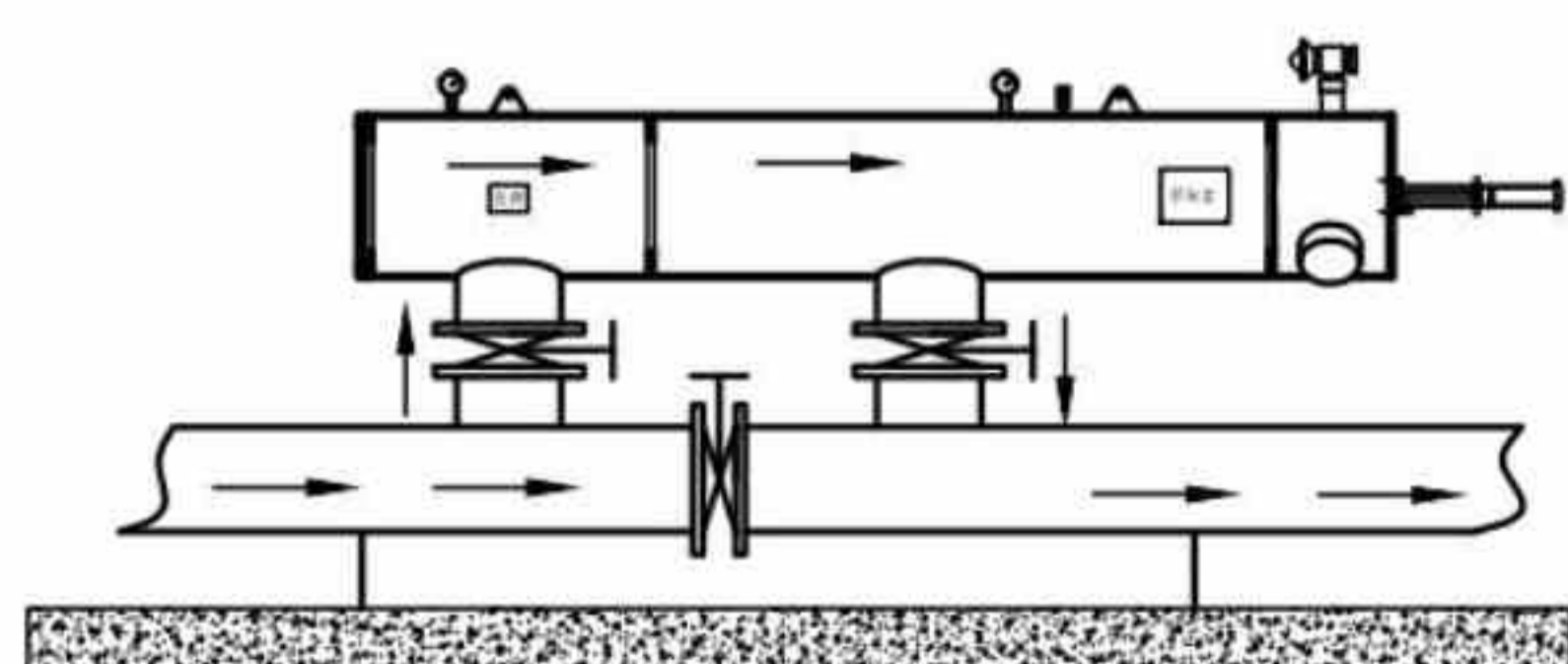

Single filter

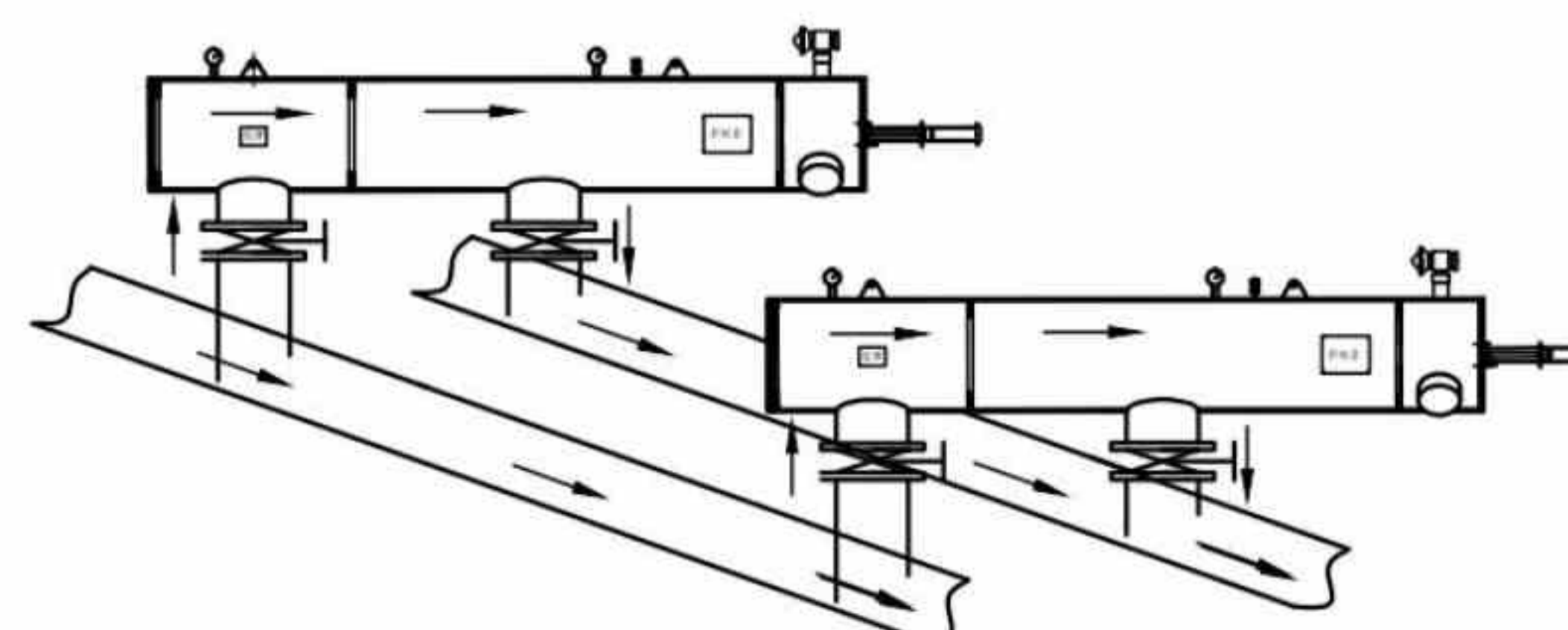

Parallel filters

\* Note: the arrow in the diagram is the direction of flow.  
Vertical or horizontal installation and multiple parallel are available.