

DLX ELECTRIC SUCKING SELF-CLEANING FILTER FL SERIES

PRINCIPLE DESCRIPTIONS

The water flows through the screen and the particles are retained on the inside of the screen of the filter element. The filtered water then flows out through the outlet.

Self-cleaning mode can be started by pressing, timing or manual three ways, following the principle of pressure difference.

When the internal and external pressure difference(ΔP) reaches the set value, the self-cleaning mode starts. Drain pipe hydraulic valve open, sucking the scanner to produce negative pressure suction nozzle inside, absorbing impurities, at the same time sucking scanner in under hydraulic motor along the inside surface mesh do reciprocating screw, movement, no cleaning blind area, impurities by the discharge outlet.

The cleaning time of self-cleaning filter is set by the controller in advance, the drain valve is closed after cleaning, and little water loss in cleaning process.



MODEL CLARIFICATION

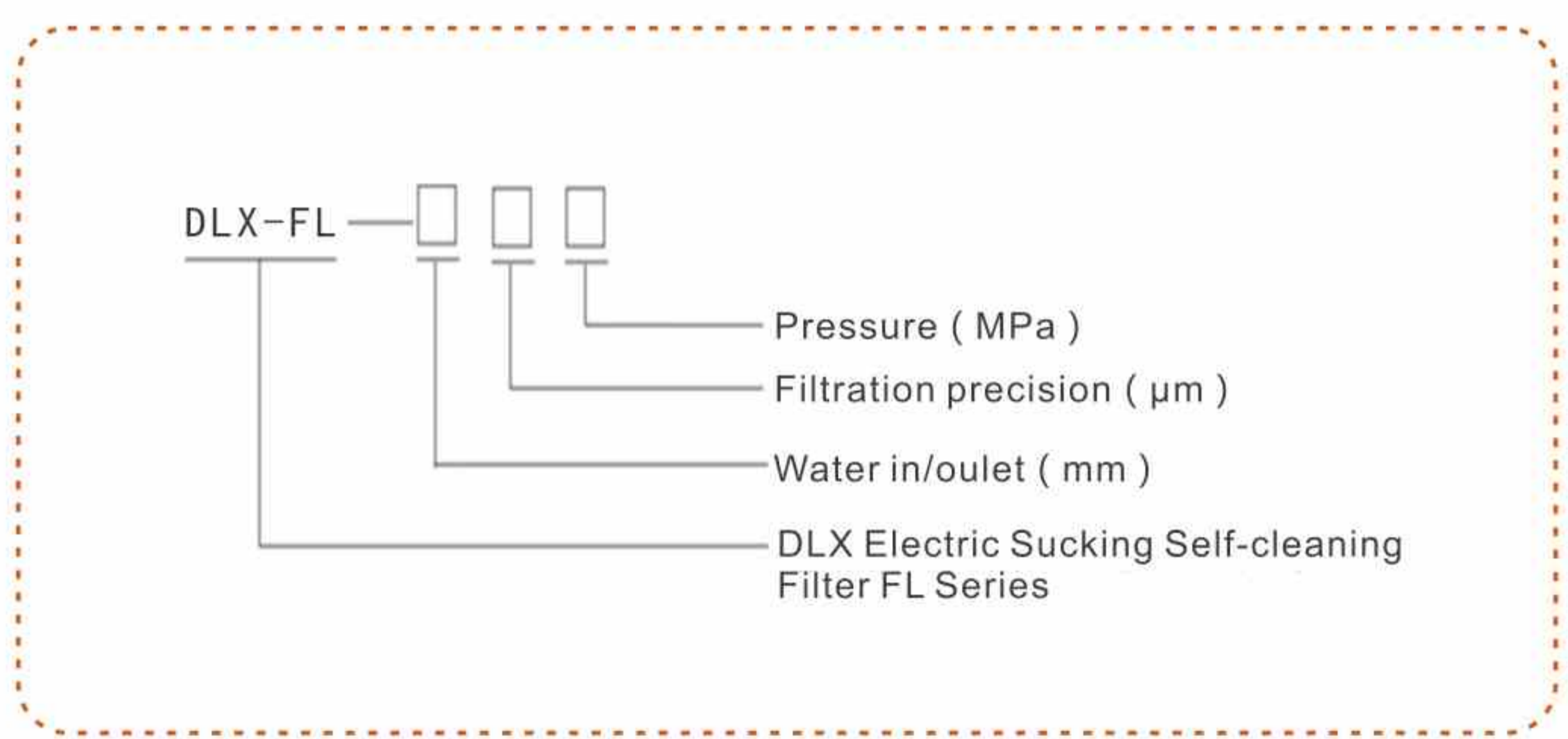

FILTER MATERIAL

- Housing: carbon steel/304 stainless steel/316L
- Mesh:304 stainless steel/316L
- Sucking scanner: 304 stainless steel/316L
- Drain valve: Casting iron, copper, stainless steel, nylon
- Sealing ring: EPDM rubber
- Control box:PVC/Aluminium

* Various materials can be provided according to the user's requirements. Please consult CDFS company for details.

TECHNICAL PARAMETERS

Single maximum filter flow:2000m ³ /h
Filtration range:4000µm~20µm
Max working pressure≤16 bar(customized)
Min working pressure≥1 bar
Working temperature≤65℃
Power:380V/50Hz(customized)
Control way: pressure difference/time/manually/PLC
Cleaning time:10~200 seconds(optional)
Drilling(4000~800µm)
Wedge(1000~50µm)
Woven composite(800~20µm)

PRODUCT STRUCTURE CHART

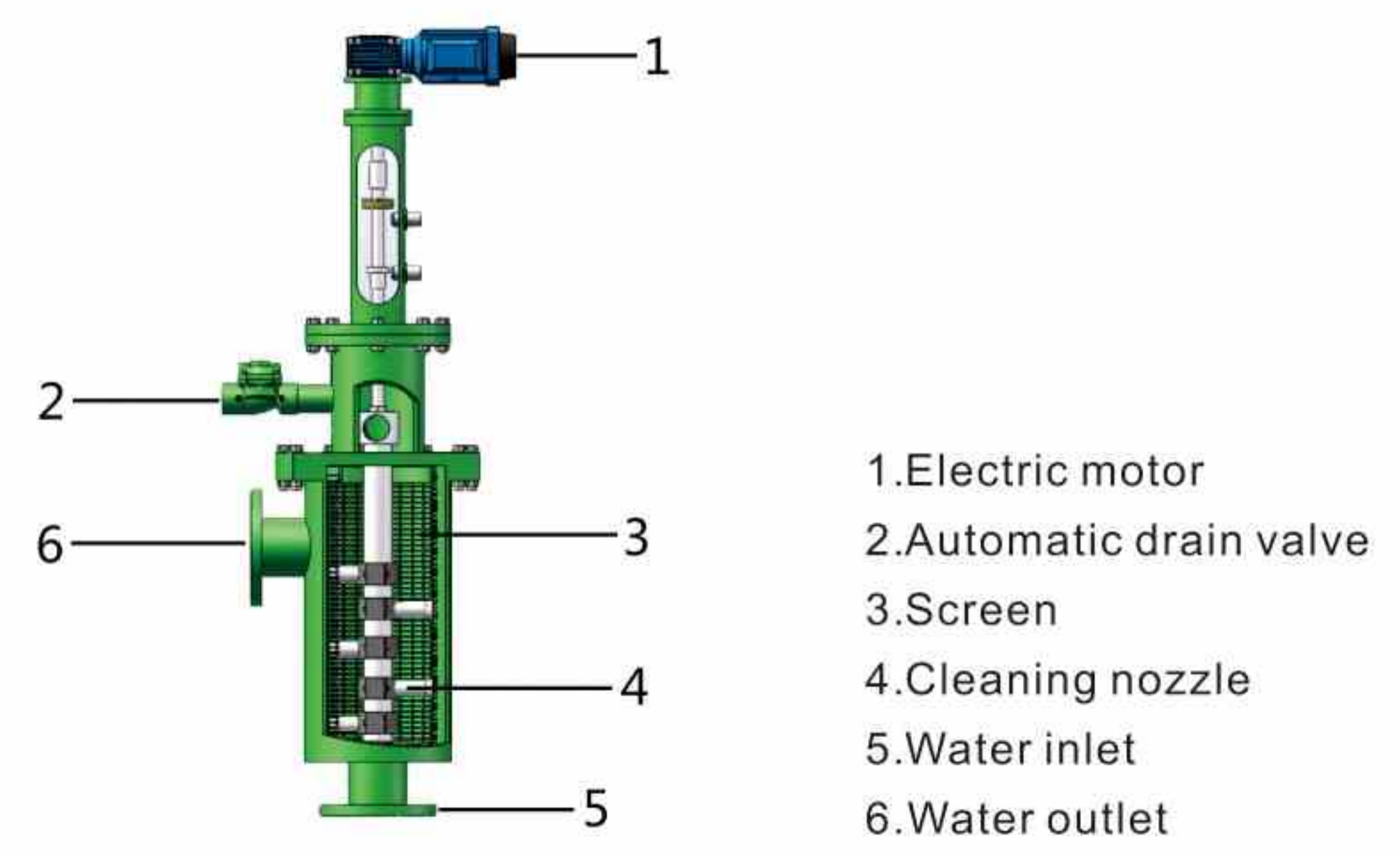

SIZE CHART

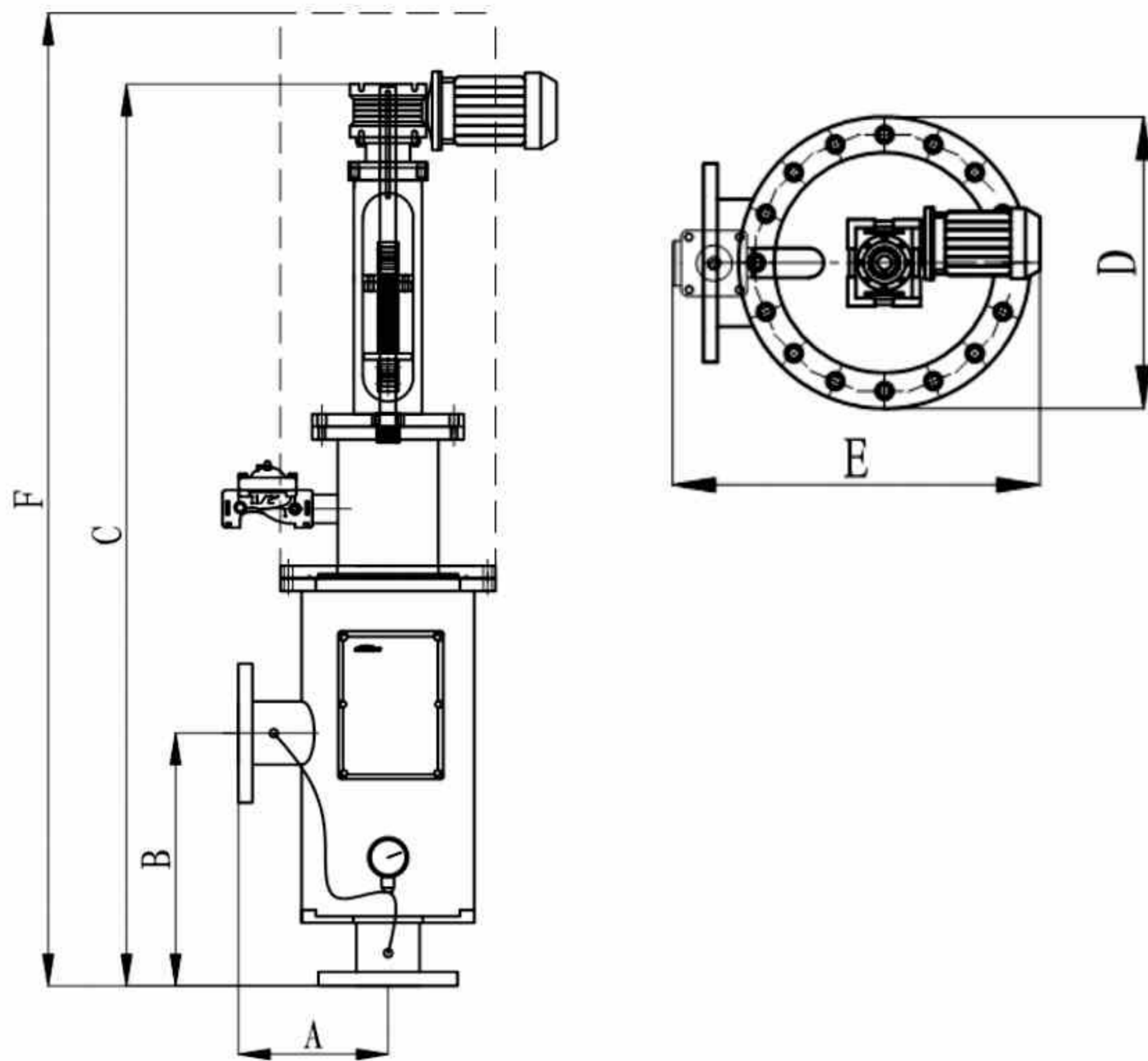

THE TABLE PRESSURE LOSS

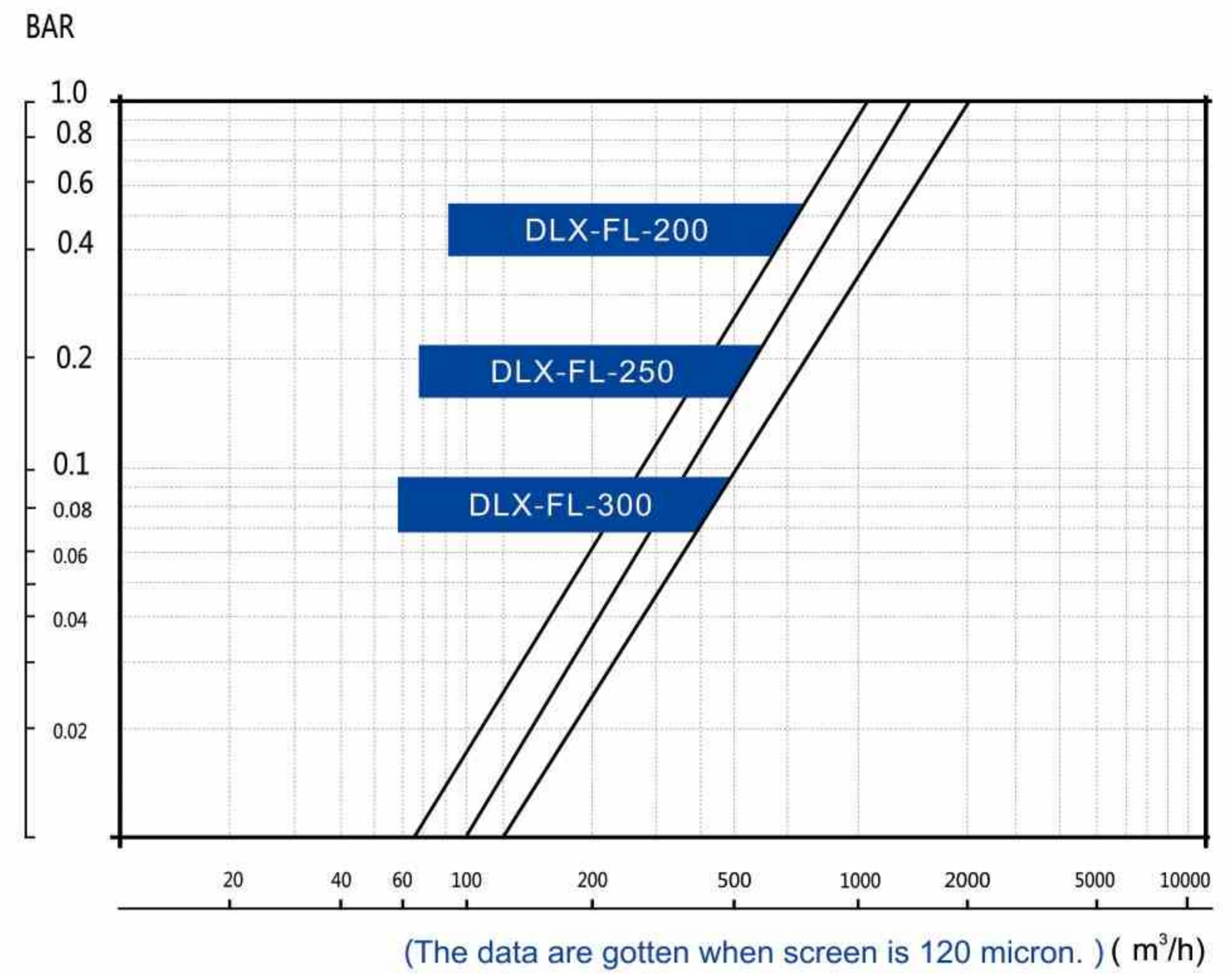

TECHNICAL DATA TABLE

MODEL	WATER IN/OUTLET (mm)	A(mm)	B(mm)	C(mm)	D(mm)	E(mm)	F(mm)	DRAIN OUTLET (mm)	FLOW (m ³ /h)	MOTOR POWER (KW)	WEIGHT (Kg)
DLX-FL-50	50	240	250	1177	560	340	1277	25	19	0.25	50
DLX-FL-65	65	240	250	1177	560	340	1277	25	30	0.25	70
DLX-FL-80	80	240	250	1177	560	340	1277	40	50	0.25	80
DLX-FL-100	100	240	400	1427	560	340	1527	40	80	0.25	105
DLX-FL-150	150	240	490	1557	560	340	1660	50	150	0.25	180
DLX-FL-200	200	285	685	2057	560	377	2260	50	320	0.25	235
DLX-FL-250	250	333	745	2270	583	426	2550	50	490	0.25	280
DLX-FL-300	300	395	830	2445	635	530	3095	50	710	0.25	420

* The actual flow is directly related to water quality and filtration precision. Please consult the company for details.

INSTALLATION FIGURE

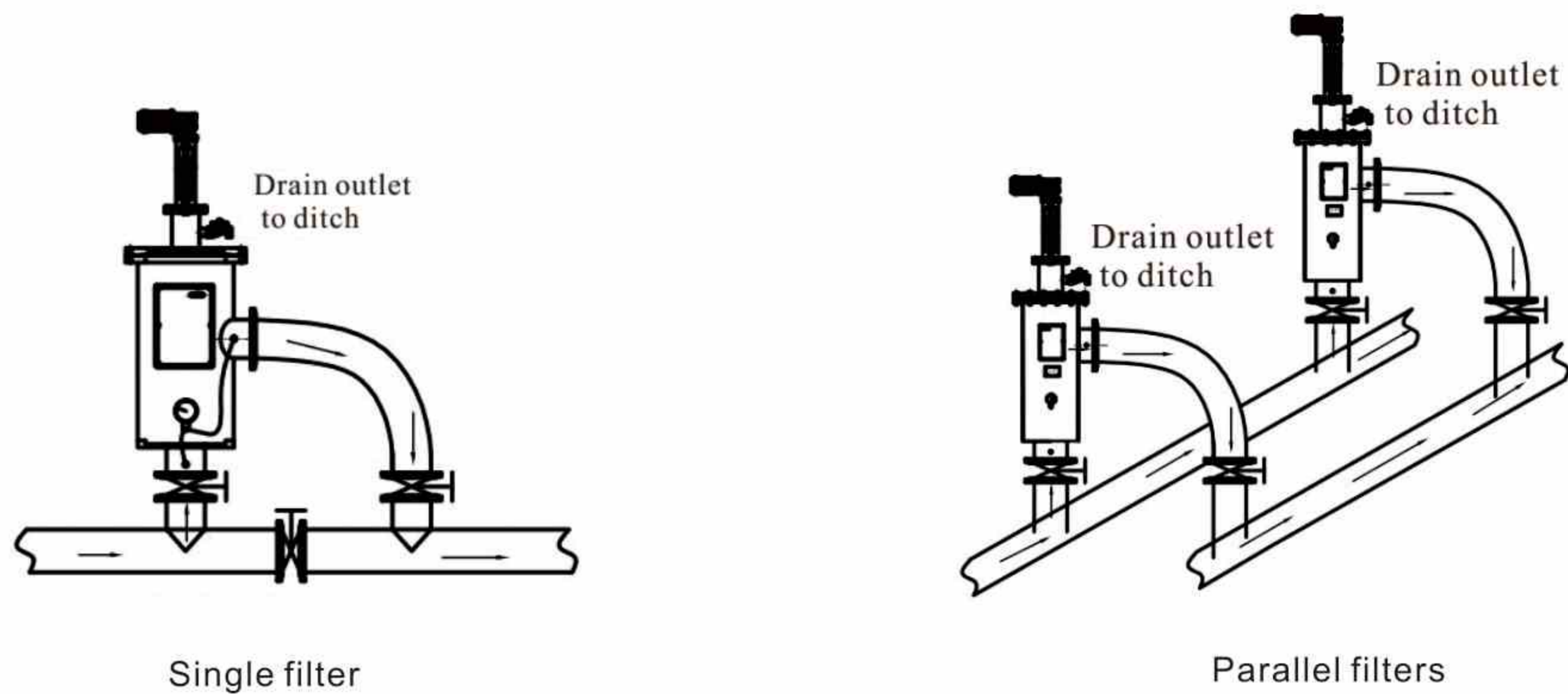

* Note: the arrow in the diagram is the direction of flow. Vertical or horizontal installation and multiple parallel are available.