



PISTON PUMP HYDRAULIC DIAPHRAGM PUMP

Manual & Digital Control

FROM WATER TREATMENT TO ADVANCED PROCESSES

The Piston & Hydraulic Diaphragm Pump series is WRS most robust series. This series provides the highest performance of high accuracy dosing in various industries. The fluid end is fully chemical resistant built, with different choices of material for different application. These series is highly customizable to fit most chemical dosing application.

PISTON (PS, PM, PL, PD, P*)



- Robust and high efficiency.
- Can deliver up to 3800 LPH per single pump head. And customizable to 20,000 LPH per single pump head.
- Pressure can pump up to 500 Bar, subject to discharge flowrate.
- Suitable for high viscosity pumping application.
- Optimized to high accuracy dosing.

HYDRAULIC DIAPHRAGM (HS, HM, HL, HD, H*)

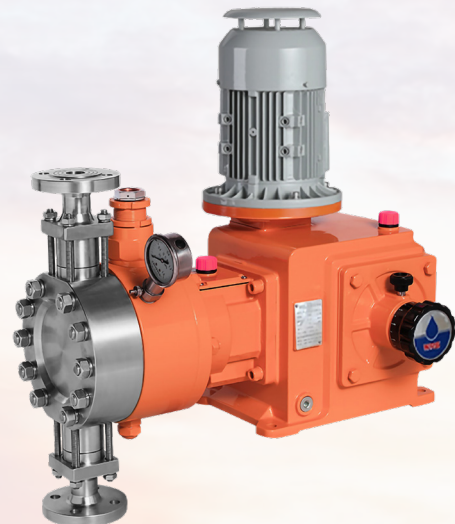





- Zero leakage design.
- Can deliver up to 3500 LPH per single pump head. And customizable to 20,000 LPH per single pump head.
- Pressure can pump up to 700 Bar, subject to discharge flowrate.
- Suitable for toxic and hazardous' medium pumping application.
- Optional to add diaphragm rupture sensor.





CONFIGURATIONS OVERVIEW

WRS pumps are designed with various configurations, offering different type of solutions to meet all of our client's requirements. From pump head design, motor types to control variants.

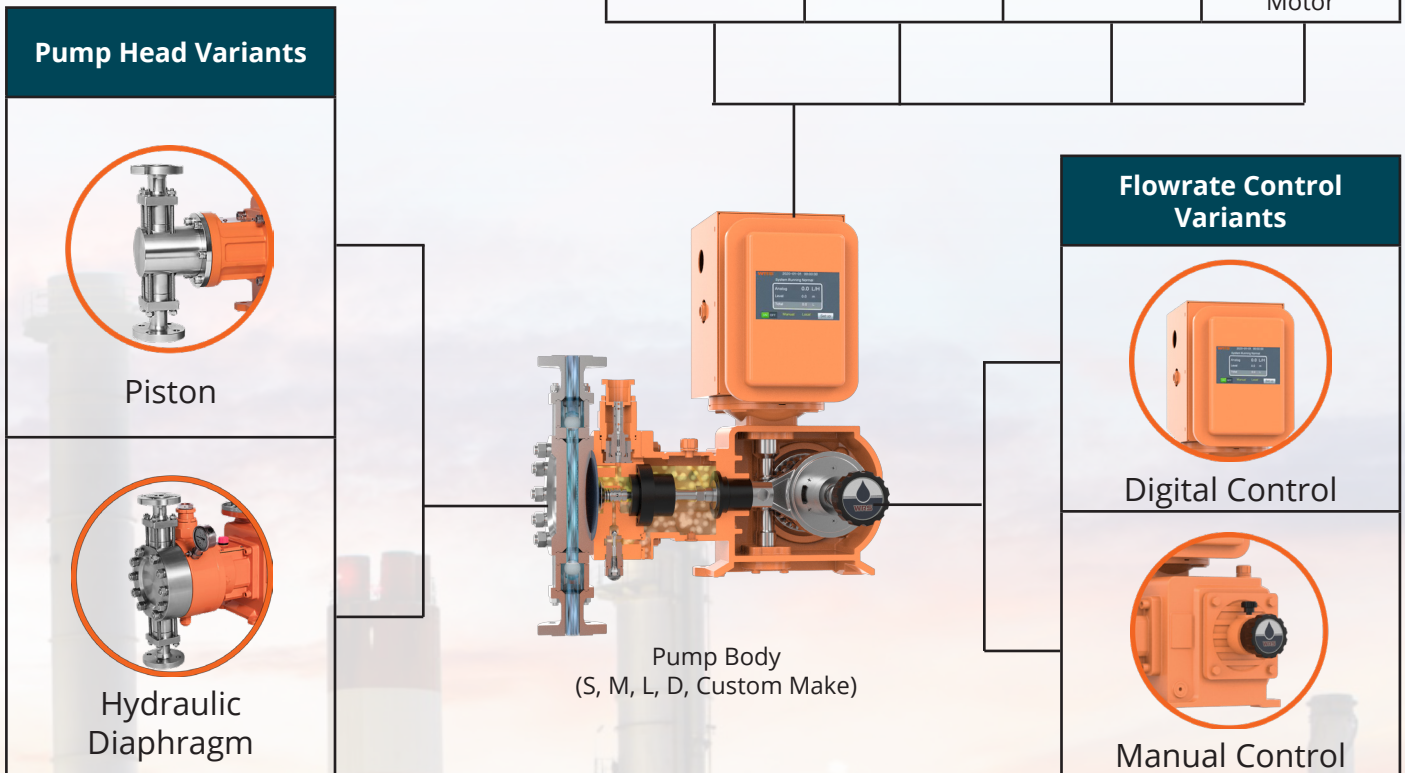
*Note: Variable Frequency motor is not required for digital control. Digital control will paired with Servo Motor / Stepper Motor to achieve flowrate control.

Motors Variants			
			
General Purpose Motor	Variable Frequency Motor	Explosion proof Motor	Explosion proof and Variable Frequency Motor



Pump Head Material	Suction and Discharge Connection Method	Pump Head Heating or Cooling	Diaphragm Rupture Sensing	Multiple Pump Head
				
Various choices of pump head material to handle different type of application.	Able to match user's requirement or factory's standard connection.	Optional pump head heating or cooling are available.	Optional extra safety features for hydraulic diaphragm pump head only.	Multiple pump head design, able to drive by 1 motor for 3 pump heads, or 1 motor for each pump head.

Note: Above configurations covers a general overview of available options for WRS piston & hydraulic diaphragm pump. For detailed selection and customization, please contact with our representative or any WRS branch.

PISTON PUMP HEAD STRUCTURE:

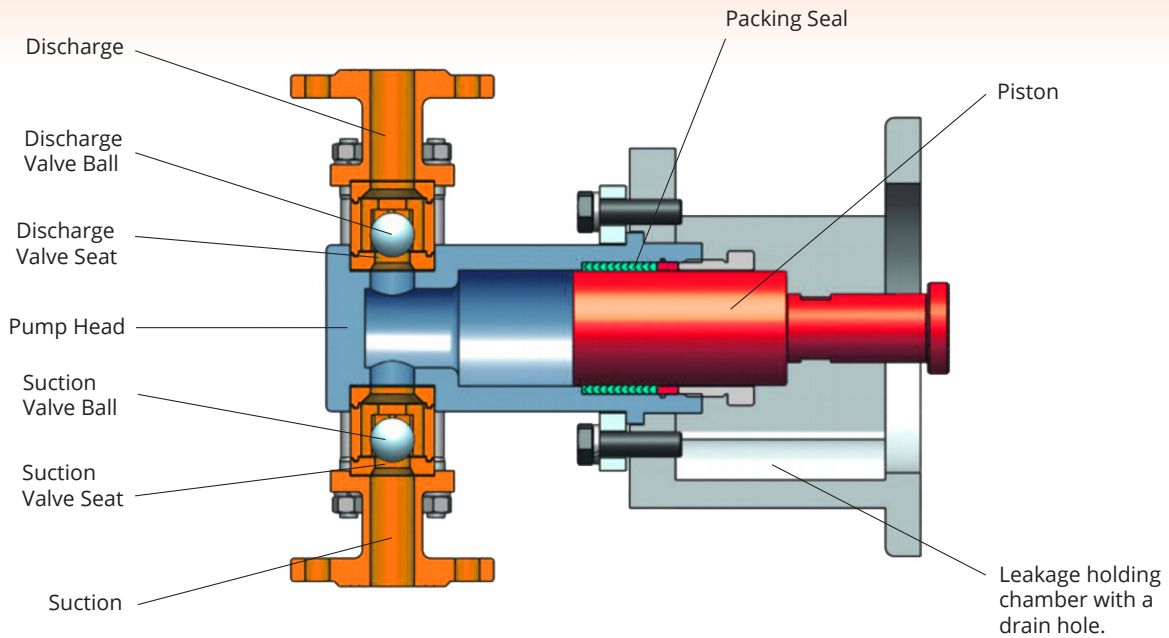

**Above cross-sectional diagram is the standard piston pump design. In this case, is a single valve ball design with flange connection. For actual pump head structures design shall be subjected to pump size, model, type, and fluid properties.*

HYDRAULIC DIAPHRAGM PUMP HEAD STRUCTURE:

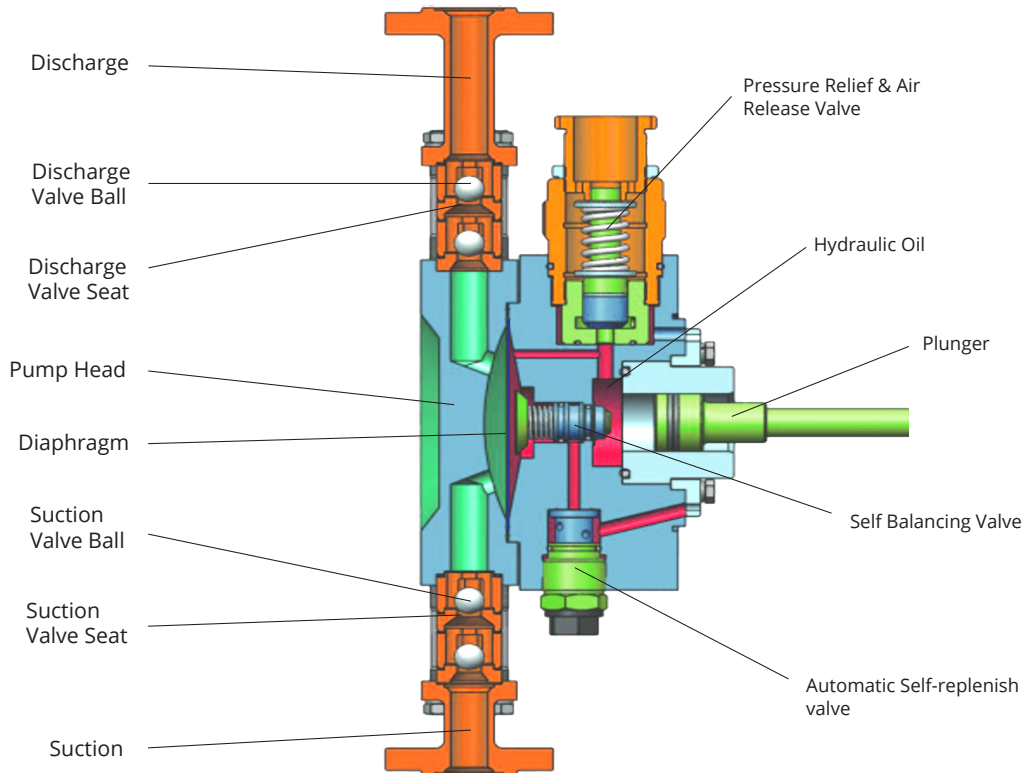

**Above cross-sectional diagram is the standard hydraulic diaphragm pump design. In this case, is a double valve ball design with flange connection. For actual pump head structures design are subjected to pump size, model, type, and fluid properties.*

COMMON PARAMETERS

Parameters	Unit	Piston Pump	Hydraulic Diaphragm Pump
Flowrate Adjustment Range		0-100% *Note1	
Accuracy	%	Steady State: 1%, Repeatability: <3%, Linearity Accuracy: <3%	
Maximum Suction Pressure	Bar	2	
Minimum Differential Pressure	Bar	1	
Maximum Suction Lift	m	5	3
Maximum Allowable Viscosity	cps	8000 *Note2	3000 *Note2
Maximum Particle Size		Particle Diameter < 0.2mm, Solid Content < 20%	
Standard Material Allowable Fluid Temperature (No Freezing Allowed)	°C	SS316L: -10 to +110 °C	PVC: +5 to +45 °C PVDF/SS316L: -10 to +110 °C Metal Diaphragm: +170 °C
Ambient Temperature	°C	Operating: 0 to +40, Storage: -10 to +50	
Ingress Protection Rating	IP	55 *Note3	
Multiple Pump Head Application *Note4		Twin Pump Head: Under same motor kW, 2 x Flowrate, Pressure / 1.3 Triple Pump Head: Under same motor kW, 3 x Flowrate, Pressure / 1.7	

***Notes:**

- 1) It is recommended to operate from 30-100% of the design flowrate to ensure 1% accuracy.
- 2) For 500 cps and above please consult with our representative.
- 3) Subject to motor IP rating.
- 4) This is a rough guide for selection phase. Please consult with our engineers when sizing multiple pump head design.

MATERIAL TABLE

Material Code	Piston Pump	Hydraulic Diaphragm Pump		
Pump Fluid End:				
Pump Head Material	SS316L	SS316L	PVC	PVDF
Piston / Diaphragm	Ceramic Surface	PTFE		
Inlet & Outlet Valve	Body	SS316L	PVC	PVDF
	Seat	SS316L	PTFE	PTFE
	Ball	Ceramic		
Seal	PTFE	PTFE	FKM	FKM
Others				
Pump Body	Cast Iron			

***Notes:**

- 1) Above material table refers to the standard models. Customizable material is available upon request.

DIGITAL CONTROL PISTON / HYDRAULIC DIAPHRAGM PUMP



Plus Series Control



Lite Series Control

*Above images are for illustration purposes only. Actual unit may be different subject to pump size, pump type, explosion proof requirements etc.

		PLUS	LITE
GENERAL			
Display Type	Touch screen HMI	√	-
	Back light LCD	-	√
Operating Method	Touch screen keypad	√	-
	Soft button (Start/stop, Up, Down)	-	√
Information Display	Current flowrate (LPH)	√	√
	Accumulated flowrate (L). Resetable.	√	√
	Current pressure/level value (Bar / m)	√	-
	Current pump status / warnings	√	-
Password Protection	To prevent unauthorized personal to make changes	√	-
CONTROL			
Manual	User may set the flow rate in litres/hour via the control panel on the pump itself (P series = touch screen, L series = soft keys) and the pump automatically adjust to dose user's set flow rate.	√	√
Signal Control	Current analog (4-20-mA). In this operating mode, the pump doses according to an external analog signal, and the flow rate being pumped is proportional to the signal input value (mA), where 4mA = 0% of the design flow rate and 20mA = 100% of the design flow rate.	√	√

		PLUS	LITE
Signal Control	Current analog reversed (20-4-mA). In this operating mode, the pump doses according to an external analog signal, and the flow rate being pumped is proportional to the signal input value (mA), where 4mA = 100% of the design flow rate and 20mA = 0% of the design flow rate.	√	√
	Current analog linear mode (mA). In this operating mode, user set 2 values, P1 & P2 (LPH). The pump doses according to an external analog signal, and the flow rate being pumped is proportional to the signal input value (mA), where 4mA = P1 of the design flow rate and 20mA = P2.	√	√
	Pulse frequency control. In this mode, user set the max. pulse frequency value (Max. 600) The pump can be controlled by receiving a pulse frequency signal from an external source. The pump doses at 100% at max pulse value and 0% at 0 pulse signal.	-	√
Remote On/Off	Dry contact (normally open). By connecting two wires, the pump can be remotely turn on/off via potential-free contacts. Typically used in programmable logic controllers (PLCs) or a level float switch.	√	√
Communication	RS485 RTU Modbus. Pumps can be remotely controlled using an Intelligent Pump Controller (IPC) by connecting to a dedicated RS485 terminal strip using a cable from the remote connection device. Common parameters include device address and baud rate.	√	√
Batch	Doses in batches based on the dosing value (in liters) set in the dosing mode. Can be activated either by receiving a pulse signal or on/off from the pump. If activating via pulse signal, one batch is dosed each time the pump receives an pulse signal.	√	√
Batch + Timer	Doses in batches based on the dosing value (in liters) at specified time. Instead of activated by pulse or pump on/off, it is activated by the timer. Up to three time points can be set in one day.	√	-
Batch Deviation	Fine tuning batch dosing accuracy. In actual application, there are many factors will affect the dosing accuracy. Users can fine tune the error by entering the differential value.	√	√
Cycle	Cycle mode runs based on the "Run Time" and "Stop Time" set by the user. Example: "Run Time" is set to 20 minutes, "Stop Time" is set to 30 minutes. When the pump starts, the pump will be run for 20 minutes, stop for 30 minutes, run for 20 minutes, stop for 30 minutes... and repeat this operation.	√	-
Timer	The timer mode runs based on timer. User to set "Start Time" and "Stop Time" in terms of HH:MM:SS. There are 3 sets of timer able to adjust per day. The timer will be repeat everyday.	√	-
OTHER FEATURES			
Low Level Alarm	Low liquid level alarm. Receive low level signal from an external dry contact.	√	-
Pressure / Level Alarm	Alarm/stop the pump according to the level/pressure set point set by the user. This pump can alarm/stop operation according to the signal from the level sensor. Choose one of the two.	√	-
Calibration Function	It has a built-in program to automatically adjust the flow rate. When the installation is complete, the user only needs to enter the actual flow rate.	√	√
Diaphragm Rupture Sensor	Optional double diaphragm rupture alarm system for safety. (For Hydraulic Diaphragm Pump Only)	√	√

PISTON PUMP IDENTIFICATION CODE

Example: PS 020 S 0 P 0 1 S 1 1 - XXX

For multiple pump head use. Empty if it is only single pump head.

For digital control use. Empty if it is a manual control pump.

For any non standard / custom make use (Factory to provide). Empty if it is according to standard design as shown in this brochure.

Example	Category	Description	
-	Pump Head Quantity	None - Single Pump Head 2 - Twin Head	3 - Triple Head X - Custom Make *2
-	Digital or Manual Control	None - Manual Control	E - With Digital Control
PS	Pump Body	PS PM PL	PD P* - Custom Make Body Size *2
-	Digital Control Method	P - Plus Series L - Lite Series	None - No Digital Control
020	Piston Size	006 - 200	
S	Pump Head Material	S - SS316L C - SS304 D - Duplex 2205	H - Hastelloy C X - Custom Make *2
0	Pump Head Heating/Cooling	0 - None 1 - Liquid/Stem Heating/Cooling	2 - Electric Heating X - Custom Make *2
P	Piston Surface Material	P - Ceramic C - Tungsten Carbide	X - Custom Make *2
0	Valve Spring	0 - No Spring 1 - Inlet Spring	2 - Outlet Spring 3 - Both Inlet & Outlet with Spring
1	Packing Seal	1 - PTFE Packing	X - Custom Make *2
S	Connection Method	S - Bevel End Welding Tube F - Flanged (user to provide flange standard)	P - Inner Thread (user to provide thread standard) X - Custom Make *2
1	Power Required	1 - 380V 50HZ 3Phase 2 - 220V 50Hz 1Phase	X - Custom Make *2
1	Motor Type	0 - No Motor 1 - IEC Motor 2 - Variable Frequency Motor	3 - Explosion Proof Motor (Exd IIB T4) 4 - Variable Frequency and Explosion Proof Motor (Exd IIB T4) X - Custom Make *2
XXX	Custom Make Code	For factory use only. Reserved for custom make selections.	

***Notes:**

1) Identification code are for identifying the pump not for complete selection. If there are any question on selection, please contact with us or our representative.

2) All custom make selection shall make confirmation with factory.

HYDRAULIC DIAPHRAGM PUMP IDENTIFICATION CODE

Example: HS 020 S 0 P 0 1 S 1 1 - XXX

For multiple pump head use. Empty if it is only single pump head.

For digital control use. Empty if it is a manual control pump.

For any non standard / custom make use (Factory to provide). Empty if it is according to standard design as shown in this brochure.

Example	Category	Description	
-	Pump Head Quantity	None - Single Pump Head 2 - Twin Head	3 - Triple Head X - Custom Make *2
-	Digital or Manual Control	None - Manual Control	E - With Digital Control
HS	Pump Body	HS HM HL	HD H* - Custom Make Body Size *2
-	Digital Control Method	P - Plus Series L - Lite Series	None - No Digital Control
020	Piston Size	006 - 200	
S	Pump Head Material	S - SS316L C - SS304 D - Duplex 2205 H - Hastelloy C	P - PVC F - PVDF T-PTFE S* - SS316L + Lined Material X - Custom Make *2
0	Pump Head Heating/Cooling	0 - None 1 - Liquid/Stem Heating/Cooling	2 - Electric Heating X - Custom Make *2
P	Diaphragm Material	P - PTFE M - Metal Diaphragm	X - Custom Make *2
0	Valve Spring	0 - No Spring 1 - Inlet Spring	2 - Outlet Spring 3 - Both Inlet & Outlet with Spring
1	Diaphragm Rupture Detection	1 - None (Single diaphragm) 2 - Double Diaphragm with Pressure Gauge Indication	3 - Double Diaphragm with Pressure Gauge + Open Contact Switch 4 - Custom Make *2
S	Connection Method	S - Bevel End Welding Tube F - Flanged (user to provide flange standard)	P - Inner Thread (user to provide thread standard) X - Custom Make *2
1	Power Required	1 - 380V 50HZ 3Phase 2 - 220V 50Hz 1Phase	X - Custom Make *2
1	Motor Type	0 - No Motor 1 - IEC Motor 2 - Variable Frequency Motor	3 - Explosion Proof Motor (Exd IIB T4) 4 - Variable Frequency and Explosion Proof Motor (Exd IIB T4) X - Custom Make *2
XXX	Custom Make Code	For factory use only. Reserved for custom make selections.	

***Notes:**

1) Identification code are for identifying the pump not for complete selection. If there are any question on selection, please contact with us or our representative.

2) All custom make selection shall make confirmation with factory.

PISTON PUMP TECHNICAL PARAMETERS

All data are tested in an indoor environment, with clean water at ambient temperature. Pumps are connected to a 50Hz power supply.

PS	Max. Flowrate (Lph)	Max. Back Pressure (Bar)		Piston Diameter (mm)	SPM	Stroke Length (mm)	Default Connection Method
		0.25 KW	0.37 KW				
006*	1	300	400	6	96	10	DN6 Bevel End Welding Tube
006*	2	230	350	6	96	20	
008	5	210	320	8	96	20	
010	8	130	200	10	96	20	
012	12	100	150	12	96	20	
016	20	50	80	16	96	20	DN10 Bevel End Welding Tube
020	35	33	50	20	96	20	
025	55	21	32	25	96	20	
032	85	13	20	32	96	20	
035	100	12	18	35	96	20	
038	125	10	16	38	96	20	DN15 Bevel End Wending Tube
042	160	7	10	42	96	20	
042	240	3	5	42	144	20	

*Notes: Please contact with our engineers or local sales representative when choosing these models.

PM	Max. Flowrate (Lph)	Max. Back Pressure (Bar)		Piston Diameter (mm)	SPM	Stroke Length (mm)	Default Connection Method
		0.55 KW	0.75 KW				
008	6	400	500	8	96	25	DN6 Bevel End Welding Tube
010	10	300	400	10	96	25	
012	15	220	300	12	96	25	
016	25	180	180	16	96	25	
020	42	70	100	20	96	25	
025	65	50	70	25	96	25	DN10 Bevel End Welding Tube
032	110	30	40	32	96	25	
038	160	20	28	38	96	25	
045	220	15	20	45	96	25	DN15 Bevel End Wending Tube
050	250	12	16	50	96	25	
055	340	8	12	55	96	25	DN25 Flange
060	400	7	10	60	96	25	
070	550	6	8	70	96	25	
065	700	4	6	65	144	25	
070	800	3	5	70	144	25	

PL	Max. Flowrate (Lph)	Max. Back Pressure (Bar)		Piston Diameter (mm)	SPM	Stroke Length (mm)	Default Connection Method
		1.1 KW	1.5 KW				
012	16	400	500	12	96	30	DN10 Bevel End Welding Tube
016	32	220	300	16	96	30	
020	50	130	180	20	96	30	
025	80	70	100	25	96	30	
032	130	60	80	32	96	30	DN15 Bevel End Wending Tube
038	200	35	50	38	96	30	
045	260	25	35	45	96	30	
050	320	22	30	50	96	30	
060	480	16	22	60	96	30	DN25 Flange
070	650	12	16	70	96	30	
080	850	9	12	80	96	30	DN40 Flange
090	1050	6	9	90	96	30	
080	1300	6	8	80	144	30	
090	1600	4	6	90	144	30	

PD	Max. Flowrate (Lph)	Max. Back Pressure (Bar)			Piston Diameter (mm)	SPM	Stroke Length (mm)	Default Connection Method
		2.2 KW	3.0 KW	4.0 KW				
012	25	400	500	500	12	96	50	DN10 Bevel End Welding Tube
016	50	300	400	500	16	96	50	
020	85	180	250	350	20	96	50	
025	130	120	160	220	25	96	50	DN15 Bevel End Wending Tube
032	220	65	90	130	32	96	50	
038	320	50	68	90	38	96	50	
045	450	35	48	70	45	96	50	DN25 Flange
050	550	30	40	56	50	96	50	
055	680	25	34	47	55	96	50	
060	800	20	28	40	60	96	50	
070	1100	15	20	28	70	96	50	DN40 Flange
075	1250	13	18	25	75	96	50	
085	1600	10	14	20	85	96	50	
095	2000	8	11	15	95	96	50	
105	2500	6	8	10	105	96	50	DN50 Flange
095	3000	5	7	9	95	144	50	
105	3800	4	5	7	105	144	50	

HYDRAULIC DIAPHRAGM PUMP TECHNICAL PARAMETERS

All data are tested in an indoor environment, with clean water at ambient temperature. Pumps are connected to a 50Hz power supply.

HS	Max. Flowrate (Lph)	Max. Back Pressure (Bar)		Piston Diameter (mm)	SPM	Stroke Length (mm)	Default Connection Method
		0.25 KW	0.37 KW				
006*	1	300	400	6	96	20	DN6 Bevel End Welding Tube
008*	2	200	300	8	96	20	
010	5	170	250	10	96	20	
010	8	120	180	10	144	20	
012	15	80	120	12	144	20	
016	30	47	70	16	144	20	DN10 Bevel End Welding Tube
020	55	27	40	20	144	20	
025	80	17	25	25	144	20	
028	100	13	20	28	144	20	
032	130	11	16	32	144	20	
035	160	8	12	35	144	20	DN15 Bevel End Welding Tube
040	220	6	10	40	144	20	

*Notes: Please contact with our engineers or local sales representative when choosing these models.

HM	Max. Flowrate (Lph)	Max. Back Pressure (Bar)		Piston Diameter (mm)	SPM	Stroke Length (mm)	Default Connection Method
		0.55 KW	0.75 KW				
008	4	400	450	8	96	25	DN6 PN700 Bevel End Welding Tube
010	6	350	400	10	96	25	
012	10	250	300	12	96	25	
012	20	150	200	12	144	25	
016	36	90	120	16	144	25	
018	48	70	100	18	144	25	DN10 PN700 Bevel End Welding Tube
020	60	60	80	20	144	25	
025	100	35	50	25	144	25	
032	160	22	30	32	144	25	DN15 PN110 Bevel End Wending Tube
036	210	18	25	36	144	25	
040	260	15	20	40	144	25	DN25 Flange
045	330	11	15	45	144	25	
050	420	9	12	50	144	25	
055	500	7	10	55	144	25	
060	600	6	8	60	144	25	
070	800	3	5	70	144	25	

Piston & Hydraulic Diaphragm Models

HL	Max. Flowrate (Lph)	Max. Back Pressure (Bar)		Piston Diameter (mm)	SPM	Stroke Length (mm)	Default Connection Method
		1.1 KW	1.5 KW				
012	12	400	450	12	96	30	DN6 Bevel End Welding Tube
016	25	250	300	16	96	30	
016	42	160	220	16	144	30	DN10 Bevel End Welding Tube
018	58	130	180	18	144	30	
020	75	110	150	20	144	30	
025	120	70	100	25	144	30	DN15 Bevel End Welding Tube
032	200	40	60	32	144	30	
036	250	33	45	36	144	30	
040	320	28	38	40	144	30	
045	400	22	30	45	144	30	DN25 Flange
050	500	18	25	50	144	30	
055	600	15	20	55	144	30	
060	720	12	16	60	144	30	
065	820	10	14	65	144	30	
070	950	9	12	70	144	30	DN40 Flange
080	1250	7	10	80	144	30	
085	1450	6	8	85	144	30	
090	1600	4	6	90	144	30	

HD	Max. Flowrate (Lph)	Max. Back Pressure (Bar)			Piston Diameter (mm)	SPM	Stroke Length (mm)	Default Connection Method
		2.2 KW	3.0 KW	4.0 KW				
012	30	400	500	700	12	144	50	DN10 Bevel End Welding Tube
016	65	250	280	400	16	144	50	
018	90	150	220	300	18	144	50	
020	125	130	180	250	20	144	50	DN15 Flange
025	200	80	100	160	25	144	50	
032	320	50	72	100	32	144	50	DN25 Flange
036	420	40	58	80	36	144	50	
040	520	35	46	65	40	144	50	
045	650	26	36	51	45	144	50	
050	800	21	29	42	50	144	50	
055	1000	17	24	34	55	144	50	DN40 Flange
060	1200	15	20	29	60	144	50	
065	1400	12	17	24	65	144	50	
070	1600	10	15	20	70	144	50	
080	2100	8	11	16	80	144	50	
085	2400	7	10	14	85	144	50	DN50 Flange
090	2600	6	8	12	90	144	50	
095	3000	5	7	11	95	144	50	
100	3500	4	6	9	100	144	50	

PISTON PUMP DIMENSION (mm)

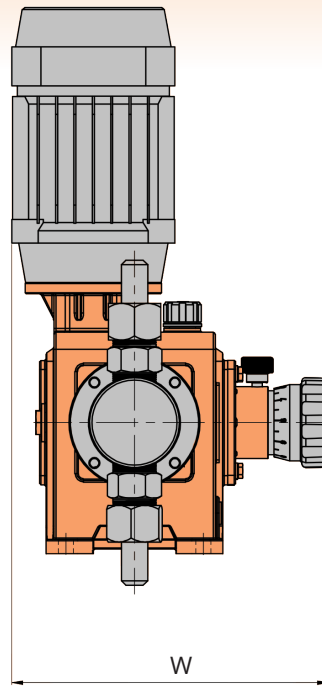
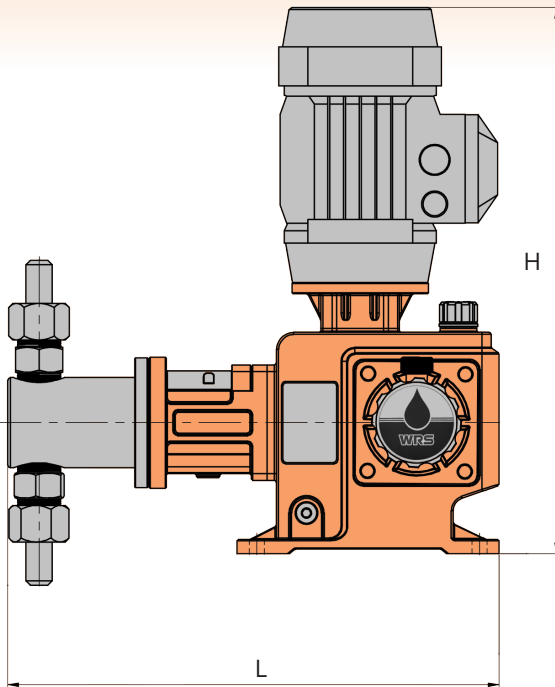

	L	W	H
PS	383	242	417
PM	492	333	480
PL	576	369	574
PD	770	506	720

HYDRAULIC DIAPHRAGM PUMP DIMENSION (mm)

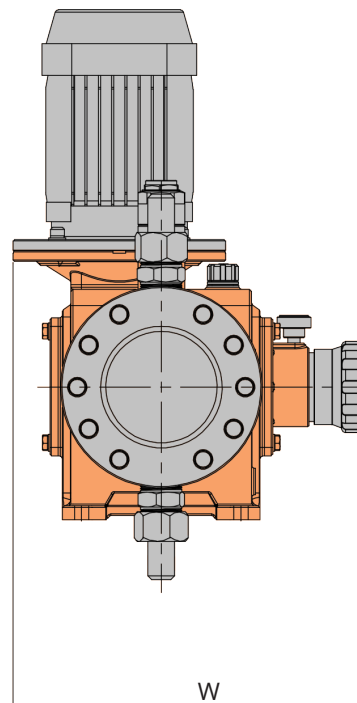
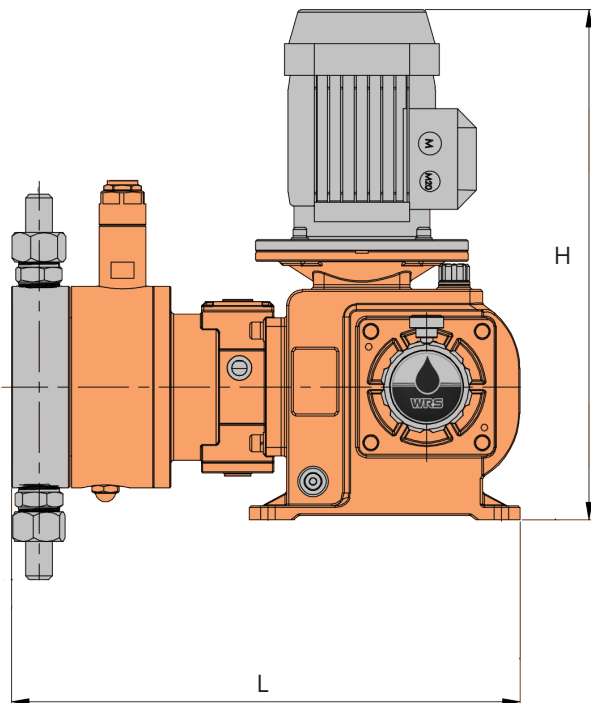

	L	W	H
HS	400	242	417
HM	518	333	481
HL	629	369	574
HD	815	507	720

All dimensions & drawing design are for reference only. Actual dimension & design subject to pump model, size, motor type, connection method, and addons.

COMPLETE DOSING SKID SOLUTIONS

Despite just being a pump manufacturer, WRS supplies a comprehensive selection of chemical dosing systems from small to large-scale applications. Our engineers have expertise in proposals regarding "plug and pump" including complete packages. We manufacture chemical dosing systems with custom-made solutions that are intended to produce available dosing technology in complete packages. Fully customizable chemical dosing systems offer a wide range of capacities to meet various chemical treatment applications.



Explosion Proof Dosing System



Large flow digital control hydraulic diaphragm pump



Process Chemical Injection Skid

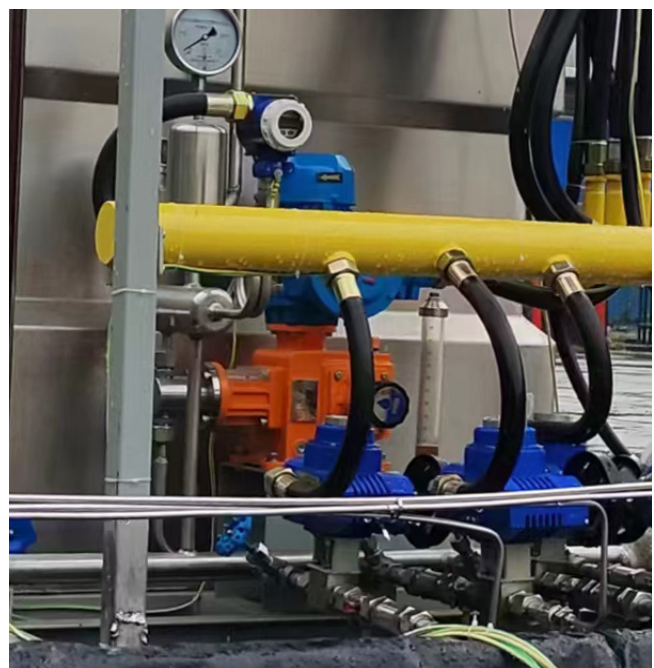

Methanol Injection Skid



WRS

Malaysia Distributor - Sales & Services



WATERMIND ENGINEERING (M) SDN. BHD.

No. 4-G, Jalan MPMU 1, Medan Perniagaan Mambau Utama, Mambau, 70300 Seremban, Negeri Sembilan.

Email: sales@watermind.com.my
Website: www.watermind.com.my

H/P: 011-7019 8596(SALES)

WRS PTE LTD
60 Paya Lebar Road, #11-37 Paya Lebar Square, Singapore 409051

ZHEJIANG WRS MACHINERY EQUIPMENT CO., LTD
501, Building 2 New World Wealth Center, 108 Shixin North Rd, Xiaoshan District, Hangzhou City, Zhejiang Province, China

Website: <https://www.wrsdosing.com>
Email: international@wrsdosing.com

ISO9001:2015
ISO14001:2015
ISO45001:2018



LL-C
Certification

